

# MOTOR VEHICLE MANUFACTURERS SPECIFICATIONS

METRIC (U.S. Customary)

## 2002

<b>Manufacturer</b> FORD MOTOR COMPANY	<b>Vehicle Line</b> FORD MUSTANG	
<b>Mailing Address</b> RESEARCH AND ENGINEERING CENTER MD 3021 P O BOX 2053 DEARBORN, MICHIGAN 48121-2053	<b>Issued</b> OCTOBER 2002	<b>Revised</b>

Direct questions concerning these specifications to the manufacturer listed above

The information contained herein is prepared, distributed by, and is the sole responsibility of the vehicle manufacturing company to whose products it relates. This suggested specification form was developed by the vehicle manufacturing company members of the Alliance of American Manufacturers (AAM) and the Association of International Automobile Manufacturers, Inc (AIAM)

The General Specifications herein after were in effect at date of compilation and are subject to change without notice or incurring obligation by the manufacturer

AAM/AIAM

Data Supplied by Member Companies

# Specifications

## Table of Contents

---

1	Vehicle Models/Origin	∅	Indicates Format Change
2	Power Teams		From Previous Year
3	Engine		
4	Lubrication System		
4	Diesel System		
5	Cooling System		
6	Fuel System		
7	Vehicle Emission Control		
7	Exhaust System		
8-10	Transmission, Axles and Shafts		
11	Suspension		
12-13	Brakes, Tires and Wheels		
14	Steering		
15-16	Electrical		
17	Body – Miscellaneous Information		
17	Frame		
18	Glass		
18	Headlamps		
19	Climate Control System		
20-21	Convenience Equipment		
21	Trailer Towing		
22-24	Vehicle Dimensions		
25	Vehicle Fiducial Marks		
26	Vehicle Mass		
27	Optional Equipment Differential Mass (Weight)		
28-34	Vehicle Dimensions Definitions – Key Sheets		
35	Index		

---

### NOTE

- 1 This form uses both SI Metric units and U S Customary units. The metric unit of measure is presented first and the U S Customary unit follows in parentheses.
- 2 UNLESS OTHERWISE INDICATED
  - a Specifications apply to standard models without optional equipment. Significant deviations are noted.
  - b Nominal design dimensions are used throughout these specifications.
  - c All linear dimensions are in millimeters (inches) and all mass (weight) specifications are in kilograms (pounds).
- 3 The General Specifications herein are those in effect at date of compilation and are subject to change without notice or incurring obligation by the manufacturer.
- 4 Additional Vehicle Dimensions (based in part on SAE J1100 "Motor Vehicle Dimensions") may be available from the manufacturer.

# Specifications

Vehicle Line MUSTANG  
 Model Year 2002 Issued 10/02 Revised (\*) \_\_\_\_\_

## METRIC

### Vehicle Origin

Design & development (company)	Ford Motor Company
Where built (country)	U S A
Authorized U S sales marketing representative	Ford Division, Ford Motor Company

### Vehicle Models

Model Description & Drive (FWD/RWD/AWD/4WD)*	Introduction Date	Make Vehicle Models Series Body Type (Mfr's Model Code)	No of Designated Seating Positions (Front/Rear)	Max Trunk/Cargo Load Kilograms (Pounds)	EPA Fuel Economy (City/Hwy)
<b>REAR WHEEL DRIVE (RWD)</b>					
<b>MUSTANG MODEL</b>					
2-Door Coupe	8/01	P40/100A/110A/120A	2 / 2	28 (62)	20 / 29
2-Door Convertible		P44/150A/160A	2 / 2	28 (62)	20 / 29
<b>MUSTANG GT MODEL</b>					
2-Door Coupe	8/01	P42/130A/140A	2 / 2	28 (62)	18 / 26
2-Door Convertible		P45/170A/180A	2 / 2	28 (62)	18 / 26

\* FWD - Front Wheel Drive RWD - Rear Wheel Drive AWD - All Wheel Drive 4WD - Four Wheel Drive

# Specifications

Vehicle Line MUSTANG  
 Model Year 2002 Issued 10/02 Revised (\*) \_\_\_\_\_

## METRIC

### Power Teams

SAE J1349 Net bhp (brake horsepower) and Net Torque corrected to 77°F/25°C and 29.61 in Hg/100 kPa atmospheric pressure

		A	B	C	D	
<b>E N G I N E</b>	Engine Code	994	994	99X	99X	
	Displacement Liters (in³)	3.8 (232)	3.8 (232)	4.6 (281)	4.6 (281)	
	Induction System (FI, Carb, etc.)	Sequential Electronic Port Fuel Injection	Sequential Electronic Port Fuel Injection	Sequential Electronic Port Fuel Injection	Sequential Electronic Port Fuel Injection	
	Compression Ratio	9.3:1	9.3:1	9.4:1	9.4:1	
	SAE Net at RPM	Power kW (bhp)	144 (193) @ 5500	144 (193) @ 5500	194 (260) @ 5250	194 (260) @ 5250
		Torque Nm (lb ft)	305 (225) @ 2800	305 (225) @ 2800	409 (302) @ 4000	409 (302) @ 4000
Exhaust single dual		Single	Single	Dual	Dual	
<b>T R A N S</b>	Transmission/ Transaxle	5-Speed Man T5OD Transmission	4-Speed Auto 4R70W Transmission	5-Speed Man T45/TR3650 Transmission	4-Speed Auto 4R70W Transmission	
	Effective Final Drive/ Axle Ratio (std. first)	3.27:1	3.27:1	3.27:1 T	3.27:1 T	

- T5OD — 5-Speed Manual Overdrive
- T45 — 5-Speed Manual Overdrive
- 4R70W — 4-Speed Electronic Automatic Overdrive
- T — Traction-Lok Included

### Series Availability

### Power Teams (A - B - C - D - E)

Model	Code	Standard	Optional
Mustang 2-Door Coupe	P40/100A/110A/120A	A	B
Mustang 2-Door Convertible	P44/150A/160A	A	B
Mustang GT 4.6L 2-Door Coupe	P42/130A/140A	C	D
Mustang GT 4.6L 2-Door Convertible	P45/170A/180A	C	D

(1) See Page 2A for Specifications

# Specifications

Vehicle Line MUSTANG  
 Model Year 2002 Issued 10/02 Revised (\*) \_\_\_\_\_

## METRIC

Engine Description  
 Engine Code

**3 8L**

## ENGINE - GENERAL

(See Page 3A for 4 6L (SOHC))

Type and description (inline, V angle flat location front mid rear transverse longitudinal sohc dohc, ohv hemi wedge pre chamber etc )

90° Front, Longitudinal, (OHV) Overhead Valve Engine with Modified Wedge Combustion Chambers

Manufacturer	Ford Motor Company	
No of cylinders	Six	
Bore	96 8 (3 8)	
Stroke	86 0 (3 4)	
Bore spacing (C/L to C/L)	106 5	
Cylinder block material & mass kg (lbs ) (machined)	Cast Iron, 58 5 (128 9)	
Cylinder block deck height	234 385 (9 2)	
Cylinder block length	411 (16 2)	
Deck clearance (minimum) (above or below block)	0 117 Below to 0 409 Above	
Cylinder head material & mass kg (lbs )	Aluminum, 7 97 (17 57)	
Cylinder head volume cm <sup>3</sup> (inches <sup>3</sup> )	63 0 (3 84)	
Cylinder liner material	N / A	
Head gasket thickness (compressed)	1 13 - 1 19 (0 044 - 0 047) 1 17 Nominal	
Minimum combustion chamber total volume cm <sup>3</sup> (inches <sup>3</sup> )	63 0 (3 84) ± 1 5 (0 09)	
Cyl no system (front to rear)*	L Bank	4, 5, 6
	R Bank	1, 2, 3
Firing order	1, 4, 2, 5, 3, 6	
Intake manifold material & mass kg (lbs)**	Aluminum, Upper 5 91 (13 0), Lower 7 73 (17 0)	
Exhaust manifold material & mass kg (lbs)**	ASTM - A269 Grade TP304L, 2 27 (5 0)	
Knock sensor (number & location)	None	
Fuel required unleaded diesel etc	Unleaded	
Fuel antiknock index (R + M) - 2	87 Minimum Octane	
Engine mounts	Quantity	Three (2 Engine, 1 Transmission)
	Material and type (elastomeric hydroelastic hydraulic damper, etc )	Engine Mounts are Elastomeric Clamshell, Transmission Mount is Shear Mount
	Added isolation (sub frame, crossmember etc )	None
Total dressed engine mass (wt) dry***	186 0 (410 0)	

## Engine - Pistons

Material & mass g (weight oz ) piston only Aluminum Alloy, WSD M2A137-B4, 448 grams

## Engine - Camshaft

Location	In Block	
Material & mass kg (weight lbs )	SAE 1050 / 1053 Steel Bar Stock and 3 713 (8 17)	
Drive type	Chain/belt	Chain (Silent)
	Width/pitch	14 91 - 13 63 (0 587 - 0 537) / 9 525 (0 375)

Rear of engine - drive takeoff View from drive takeoff end to determine left & right side of engine

\*\* Finished state

\*\*\* Dressed engine mass (weight) includes the following From: End Dress, All Engine Mounted Components and Flex Plate, Excludes Starter and Alternator

# Specifications

Vehicle Line MUSTANG  
 Model Year 2002 Issued 10/02 Revised (\*) \_\_\_\_\_

## METRIC

Engine Description  
 Engine Code

**4.6L (SOHC)**

### ENGINE - GENERAL

(See Page 3 for 3.8L)

Type and description (inline V angle flat location front mid rear transverse, longitudinal sohc dohc ohv hemi wedge pre-chamber etc)	90° V-8, Front, Longitudinal, Single Overhead Cam (SOHC), Two Valves Per Cylinder	
Manufacturer	Ford Motor Company	
No of cylinders	Eight	
Bore	90.2 (3.6)	
Stroke	90.0 (3.6)	
Bore spacing (C/L to C/L)	100.0 (3.9)	
Cylinder block material & mass kg (lbs) (machined)	Cast Iron, 69.9 (154.0)	
Cylinder block deck height	277.0 (8.9)	
Cylinder block length	500.5 (19.7)	
Deck clearance (minimum) (above or below block)	343 (0.14) Below	
Cylinder head material & mass kg (lbs)	Aluminum, 15.0 (33.0)	
Cylinder head volume cm <sup>3</sup> (inches <sup>3</sup> )	50.3 (3.07)	
Cylinder liner material	N/A	
Head gasket thickness (compressed)	0.89 (0.035)	
Minimum combustion chamber total volume cm <sup>3</sup> (inches <sup>3</sup> )	65.4 (3.99)	
Cyl no system (front to rear)	L Bank	5, 6, 7, 8
	R Bank	1, 2, 3, 4
Firing order	1, 3, 7, 2, 6, 5, 4, 8	
Intake manifold material & mass kg (lbs)**	Composite, 10.0 (4.5)	
Exhaust manifold material & mass kg (lbs)**	Cast Iron Nodular, 9.5 (20.9)	
Knock sensor (number & location)	No	
Fuel required unleaded diesel etc	Unleaded	
Fuel antiknock index (R + M) - 2	87 Minimum Octane	
Engine mounts	Quantity	Three (2 Engine, 1 Transmission)
	Material and type (elastomeric hydroelastic hydraulic damper etc)	Engine Mounts are Elastomeric Clamshell, Transmission Mount is Shear Mount
	Added isolation (sub frame crossmember etc)	None
Total dressed engine mass (wt) dry **	(522) Manual Transmission, (484) Automatic Transmission	

### Engine - Pistons

Material & mass g (weight oz) piston only	Hypereutectic Aluminum Alloy, 356 (12.6)
---	--

### Engine - Camshaft

Location	In Cylinder Head	
Material & mass kg (weight lbs)	Tubular Steel, 2.54 (5.6) Each, 5.1 (11.2) Total Per Engine	
Drive type	Chain/belt	Chain, Inverted Tooth
	Width/pitch	13.0 (0.51) / 9.5 (0.37)

\* Rear of engine - drive takeoff View from drive takeoff end to determine left & right side of engine

\*\* Finished state

\*\*\* Dressed engine mass (weight) includes the following Front End Dress, All Engine Mounted Components and Flex Plate, Excludes Starter

# Specifications

Vehicle Line MUSTANG  
 Model Year 2002 Issued 10/02 Revised (\*) \_\_\_\_\_

## METRIC

Engine Description  
 Engine Code

3 8L

### Engine – Valve System

Hydraulic lifters (std , opt n a )	Standard with Roller Tappets
Valves	Number intake/exhaust   6 / 6
	Head O D intake/exhaust   47 27 (1 86) / 37 1 (1 46)

### Engine – Connecting Rods

Material & mass kg (weight lbs )*	Powered Metal, 486 – 492 grams (Crank Pin In)
Length (axes C/L to C/L)	154 66 - 154 74 (6 08 - 6 09)

### Engine – Crankshaft

Material & mass kg (weight lbs )*	Nodular Cast Iron, 14 51 (32 0)
End thrust taken by bearing (no )	#3
Length & number of main bearings	4
Seal (material one, two piece design etc )	Front   Flourocarbon, One Piece
	Rear   Flourocarbon, Dual Lip

### Engine – Lubrication System

Normal oil pressure kPa (psi) at engine rpm	276 – 414 (40 – 60) @ 2000 RPM
Type oil intake (floating stationary)	Stationary Shrouded Screen in Sump
Oil filter system (full flow part other)	Full Flow
Capacity of c/case less filter-refill L (qt)	4 5 (4 8) Plus 0 5 (0 5) for Filter

### Engine – Diesel Information

(NOT OFFERED)

Diesel engine manufacturer	
Glow plug current drain at 0°F	
Injector nozzle	Type
	Opening pressure kPa (psi)
Pre chamber design	
Fuel injection pump	Manufacturer
	Type
Fuel injection pump drive (belt chain gear)	
Supplementary vacuum source (type)	
Fuel heater (yes/no)	
Water separator description (std opt )	
Turbo manufacturer	
Oil cooler-type (oil to engine coolant oil to ambient air)	
Oil filter	

### Engine – Intake System

(NOT OFFERED)

Turbo charger manufacturer	
Super charger - manufacturer	
Intercooler	

\* Finished state

# Specifications

Vehicle Line MUSTANG  
 Model Year 2002 Issued 10/02 Revised (\*) \_\_\_\_\_

## METRIC

Engine Description  
 Engine Code

**4 6L (SOHC) w/GT**

### Engine - Valve System

Hydraulic lifters (std, opt, n/a)	Hydraulic Lash Adjuster (with Roller Follower)
Valves	Number intake/exhaust 8 / 8
	Head O D intake/exhaust 44.5 (1.75) / 36 (1.42)

### Engine - Connecting Rods

Material & mass kg (weight lbs)*	Powered Metal Forging, 0.58 (1.28)
Length (axes C/L to C/L)	150.7 (5.93)

### Engine - Crankshaft

Material & mass kg (weight lbs)*	Nodular Cast Iron, 19.6 (43.3)
End thrust taken by bearing (no)	#5
Length & number of main bearings	19 (0.75), 5
Seal (material one two piece design etc)	Front Fluoroelastomer, One Piece
	Rear Fluoroelastomer, One Piece with Slinger

### Engine - Lubrication System

Normal oil pressure kPa (psi) at engine rpm	276 - 414 (40 - 60) @ 2000 RPM
Type oil intake (floating, stationary)	Stationary Shrouded Screen in Sump
Oil filter system (full flow, part other)	Full Flow
Capacity of c/case less filter-refill L (qt)	5.7 (6.0) Less 0.47 (0.5) for Filter

### Engine - Diesel Information

(NOT OFFERED)

Diesel engine manufacturer	
Glow plug current drain at 0°F	
Injector nozzle	Type
	Opening pressure kPa (psi)
Pre-chamber design	
Fuel injection pump	Manufacturer
	Type
Fuel injection pump drive (belt chain gear)	
Supplementary vacuum source (type)	
Fuel heater (yes/no)	
Water separator description (std, opt)	
Turbo manufacturer	
Oil cooler type (oil to engine coolant oil to ambient air)	
Oil filter	

### Engine - Intake System

(NOT OFFERED)

Turbo charger manufacturer	
Super charger manufacturer	
Intercooler	

\* Finished state



# Specifications

Vehicle Line MUSTANG

Model Year 2002

Issued 10/02

Revised (\*)

## METRIC

Engine Description  
Engine Code

3 8L

### Engine – Cooling System

(See Page 5A for 4 6L (SOHC))

Coolant recovery system (std opt n/a)	Standard	
Coolant fill location (rad bottle)	Radiator Coolant Fill, Bottle Coolant Add	
Radiator cap relief valve pressure kPa (psi)	97 – 127 (14 – 18) Mean 110 (16)	
Circulation thermostat	Type (choke bypass)	Reverse Poppet
	Starts to open at °C (°F)	91 7° (197°)
Water pump	Type (centrifugal, other)	Centrifugal
	GPM 1000 pump rpm	10
	Number of pumps	One
	Drive (V belt other)	Six Rib Poly V
	Bearing type	Double Row, Sealed, Ball and Roller
	Impeller material	Low Carbon Steel
	Housing material	Die Cast Aluminum
By pass recirculation type (inter ext)	External	
Cooling system capacity	With heater – L/qt)	11 9 (12 6)
	With air conditioner – L/qt)	11 9 (12 6)
	Opt equipment specify – L/qt)	N / A
Water jackets full length of cyl (yes no)	No	
Water all around cylinder (yes no)	Yes	
Water jackets open at head face (yes no)	No	
Radiator core	Std A/C HD	Standard
	Type (cross flow etc)	Cross-Flow
	Construction (in & tube mechanical braze etc)	Tube and Fin Controlled Atmosphere Brazed
	Material mass kg (wgt lbs)	Aluminum, 4 6 (10 2)
	Width	635 0 (25 0)
	Height	434 0 (17 1)
	Thickness	25 9 (1 0)
Fins per decimeter	85 (FPDM)	
Radiator end tank material	30% Glass Filled Nylon	
Fan	Std elec opt	Electric Driven
	Number of blades & type (flex solid material)	Six Blade Nylon Ring
	Number & location (front rear of radiator)	Rear of Radiator
	Diameter & projected width	445 MM
	Ratio (fan to crankshaft rev)	N / A
	Fan cutout type	N / A
	Drive type (direct remote)	N / A
	RPM at idle (elec)	1600
	Motor rating (wattage/elec)	300
	Motor switch (type & location/elec)	Electncal – EEC Control
Switch point (temp /pressure/elec)	Electncal – EEC Control 102°C (216°F)	
Fan shroud (material)	Glass and Mineral Filled Nylon	

# Specifications

Vehicle Line MUSTANG  
 Model Year 2002 Issued 10/02 Revised (r) \_\_\_\_\_

## METRIC

Engine Description  
 Engine Code

**4 6L (SOHC) MUSTANG GT**

### Engine - Cooling System

(See Page 5 for 3 8L)

Coolant recovery system (std , opt n a )	Standard, Quiescent Bottle	
Coolant fill location (rad bottle)	Bottle	
Radiator cap relief valve pressure kPa (psi)	110 0 (16 0)	
Circulation thermostat	Type (choke bypass)	Bypass
	Starts to open at °C (°F)	90 6° (195°)
Water pump	Type (centrifugal other)	Centrifugal
	GPM 1000 pump rpm	10
	Number of pumps	One
	Drve (V belt other)	Poly V-Belt
	Bearing type	Ball and Roller
	Impeller material	Stamped Steel
	Housing material	Die Cast Aluminum
By pass recirculation type (inter , ext )	Internal	
Cooling system capacity	With heater - L(qt )	14 0 (14 8)
	With air conditioner - L(qt )	14 0 (14 8)
	Opt equipment specity - L(qt )	N / A
Water jackets full length of cyl (yes no)	Yes	
Water all around cylinder (yes no)	Yes	
Water jackets open at head face (yes no)	Yes	
Radiator core	Std , A/C HD	Standard
	Type (cross-flow etc )	Cross-Flow
	Construction (fin & tube mechanical braze etc )	Tube and Center, Controlled Atmosphere Brazed
	Material mass kg (wgt lbs )	Aluminum 4 6 (10 2)
	Width	635 0 (25 0)
	Height	434 0 (17 1)
	Thickness	25 9 (1 0)
	Fins per decimeter	85 (FPDM)
Radiator end tank material	30% Glass Filled Nylon Ring	
Fan	Std elec opt	Electnc
	Number of blades & type (flex solid material)	Six Blade Nylon Ring
	Number & location (front rear of radiator)	Rear of Radiator
	Diameter & projected width	445 mm
	Ratio (fan to crankshaft rev )	N / A
	Fan cutout type	N / A
	Drve type (direct remote)	N / A
	RPM at idle (elec )	Low Speed 1760, High Speed 1870
	Motor rating (wattage/elec )	Low Speed 299, High Speed 414
	Motor switch (type & location/elec )	Electrcal - EEC Control
	Switch point (temp ,pressure/elec )	Electrcal - EEC Control 102°C (216°)
Fan shroud (material)	Glass and Mineral Filled Nylon	

# Specifications

Vehicle Line MUSTANG  
 Model Year 2002 Issued 10/02 Revised (\*) \_\_\_\_\_

## METRIC

Engine Description  
 Engine Code

3 8L

4 6L (SOHC)

### Engine – Fuel System (See supplemental page for details of Fuel Injection Supercharger, Turbocharger, etc if used)

Induction type carburetor fuel injection system etc	Sequential Electronic Port Fuel Injection System	
Manufacturer	Ford Motor Company	
Carburetor no of barrels	N / A	
Idle A/F mix	14 6 1 Closed Loop	
Fuel Injection	Point of injection (no )	Intake Ports (6) Intake Ports (8)
	Constant pulse flow	Timed Pulse
	Control (electronic mech )	Electronic
	System pressure kPa (psi)	Variable
Idle spd rpm (spec neutral or drive and propane if used)	Manual	720 (Neutral) 656 (Neutral)
	Automatic	720 (Neutral) 656 (Neutral), 560 (Drnve)
		640 (Drnve) (Federal), 670 (Drnve) (California) 690 (Drnve) w/AC On
Intake manifold heat control (exhaust or water thermostatic or fixed)	None	
Air cleaner type	Conical, Wetted Media, Replaceable Element	
Fuel filter (type/location)	FG-800, Below Vehicle Near Fuel Tank	
Fuel Pump	Type (elec or mech )	Electric
	Location (eng tank)	Fuel Tank
	Pressure range kPa (psi)	0-80 PSIG, Variable
	Flow rate at regulated pressure L (gal)/hr @ kPa (psi)	165 LpH @ 350 kPa 175 LpH @ 310 kPa (ERFS)

### Fuel Tank

Capacity re-fill L (gallons)	59 4 (15 7)	
Location (describe)	Behind Rear Axle	
Attachment	Two Straps, Pin and Loop at LH Rear, Bolt at Front of Tank and RH Rear	
Material & Mass kg (weight lbs )	Steel (ZnNi Electro Plate) and 9 1 (20 0)	
Filter pipe	Location & material	Right Rear Quarter Panel – Steel
	Connection to tank	Rubber Seal
Fuel line (material)	Steel / Covered Nylon	
Fuel hose (material)	Covered Nylon	
Return line (material)	Steel / Covered Nylon	
Vapor line (material)	Steel / Covered Nylon	
Extended range tank	Opt n a	N / A
	Capacity L (gallons)	—
	Location & material	—
	Attachment	—
Auxiliary tank	Opt n a	N / A
	Capacity L (gallons)	—
	Location & material	—
	Attachment	—
	Selector switch or valve	—
Separate fill	—	

# Specifications

Vehicle Line MUSTANG  
 Model Year 2002 Issued 10/02 Revised (\*) \_\_\_\_\_

## METRIC

Engine Description  
 Engine Code

**3 8L**

## Vehicle Emission Control

(See Page 7A for 4 6L (SOHC))

Exhaust Emission Control	Type (air injection engine modifications other)		Vehicle and Engine Modifications, Plus Exhaust Gas Recirculation
	Air Injection	Pump or pulse	N / A
		Driven by	N / A
		Air distribution (head manifold etc)	N / A
		Point of entry	N / A
	Exhaust Gas Recirculation	Type (controlled flow open orifice other)	Delta PFE (DPFE)
		Exhaust source	RH Exhaust Manifold
		Point of exhaust injection (spacer carburetor manifold other)	Intake Manifold (Lower)
	Catalytic Converter	Type	TWC
		Number of	Six (6)
		Location (s)	TWC (2) — Toeboard and TWC (4) — Underbody
		Volume L (m <sup>3</sup> )	Federal and Green States Toeboard 2 x (31), Underbody 2 x (42) x 2 (42)
		Substrate type	Ceramic
		Noble metal type	Pd Palladium (Toeboard), Pd Palladium/RL Rhodium (Underbody)
	Crankcase Emission Control	Noble metal concentration (g/g <sup>2</sup> )	Toeboard 200, Underbody 60
Type (ventilates to atmosphere induction system other)		Closed Induction System	
Energy source (manifold vacuum carburetor other)		Manifold Vacuum	
Discharges to (intake manifold other)		Intake Manifold	
Evaporative Emission Control	Air inlet (breather cap other)		Air Inlet Tube
	Vapor vented to (crankcase canister other)	Fuel tank	Externally Vented to Carbon Canister
		Carburetor	N / A
Vapor storage provision		Carbon Canister	
Electronic system	Closed loop (yes/no)		Yes
	Open loop (yes/no)		Yes

## Engine - Exhaust System

Type (single single with cross-over dual other)		Single with Dual Catalyst System
Muffler no & type (reverse flow straight thru separate resonator) Material & Mass kg (weight lbs)		One, Reverse Flow, 409 Stainless Steel, (20 8)
Resonator no & type		N / A
Exhaust pipe	Branch o d wall thickness	—
	Main o d wall thickness	—
	Material & Mass kg (weight lbs)	—
Intermediate pipe	o d & wall thickness	57 2 x 1 37 (2 25 x 054)
	Material & Mass kg (weight lbs)	409 Stainless Steel (Weight Included in Muffler)
Tail pipe	o d & wall thickness	57 2 x 1 37 (2 25 x 054)
	Material & Mass kg (weight lbs)	409 Stainless Steel (Weight Included in Muffler)

# Specifications

Vehicle Line MUSTANG  
 Model Year 2002 Issued 10/02 Revised (\*) \_\_\_\_\_

## METRIC

Engine Description  
 Engine Code

**4 6L (SOHC)**

### Vehicle Emission Control

(See Page 7 for 3.8L)

	Type (air injection, engine modifications other)	Vehicle and Engine Modifications Exhaust Gas Recirculation and Air Injection
Air Injection	Pump or pulse	N / A
	Driven by	—
	Air distribution (head manifold etc)	—
	Point of entry	—
Exhaust Gas Recirculation	Type (controlled flow open orifice other)	Electronic
	Exhaust source	LH Exhaust Manifold
	Point of exhaust injection (spacer carburetor manifold other)	Throttle Body Spacer
Catalytic Converter	Type	TWC
	Number of	Four
	Location (s)	Two (2) Toeboard and Four (2) Underbody (Federal and Green States)
	Volume L (in <sup>3</sup> )	Toeboard - (2) x 0.69 (42) and Underbody - (4) x 0.69 (42)
	Substrate type	
	Noble metal type	Pd Palladium
	Noble metal concentration (g/ft <sup>3</sup> )	110 for all cars
Crankcase Emission Control	Type (ventilates to atmosphere induction system other)	Closed Induction System
	Energy source (manifold vacuum carburetor other)	Intake Manifold Vacuum
	Discharges to (intake manifold, other)	Intake Manifold
	Air inlet (breather cap other)	Air Inlet Tube
Evaporative Emission Control	Vapor vented to (crankcase canister other)	Fuel tank Carburetor
	Vapor storage provision	Carbon Canister N / A
Electronic system	Closed loop (yes/no)	Yes
	Open loop (yes/no)	Yes

### Engine - Exhaust System

Type (single, single with cross over dual other)	Dual with Cast Iron Exhaust Manifolds	
Muffler no & type (reverse flow straight thru separate resonator) Material & Mass kg (weight lbs)	Two, Reverse Flow 409 Stainless Steel and LH - 9.26 (20.4), RH - 9.4 (20.6)	
Resonator no & type	N / A	
Exhaust pipe	Branch o.d. wall thickness	—
	Main o.d. wall thickness	—
	Material & Mass kg (weight lbs)	—
Intermediate pipe	o.d. & wall thickness	57.2 x 1.2 - 1.35 (2.25 x 0.047 - 0.053)
	Material & Mass kg (weight lbs)	409 Stainless Steel
Tail pipe	o.d. & wall thickness	61.2 x 1.3 - 1.45 (2.50 x 0.051 - 0.057)
	Material & Mass kg (weight lbs)	409 Stainless Steel with Bright 304 Stainless Steel Outlets

# Specifications

Vehicle Line MUSTANG  
 Model Year 2002 Issued 10/02 Revised (\*) \_\_\_\_\_

## METRIC

Engine Description  
 Engine Code

3 8L

### Transmissions/Transaxle (Std , Opt , N A ) (See Page 8A for 4 6L)

Manual 4 speed (manufacturer/country)	N / A
Manual 5 speed (manufacturer/country)	Standard (Tremec / Mexico)
Manual 6 speed (manufacturer/country)	N / A
Automatic (manufacturer/country)	N / A
Automatic overdrive (manufacturer/country)	Optional 4-Speed (Ford / USA)

### Manual Transmission/Transaxle

Number of forward speeds	Five	
Gear ratios	1st	3 35
	2nd	1 99
	3rd	1 33
	4th	1 00
	5th	0 68
	6th	—
	Reverse	3 15
Synchronous meshing (specify gears)	All Forward Gears	
Shift lever location	Floor	
Trans case matl & mass kg (lbs)*	Aluminum and 46 77 (103 1)	
Lubricant	Capacity L (pt)	2 6 (5 6)
	Type recommended	Dexron III

### Clutch (Manual Transmission)

Clutch manufacturer	Luk Inc	
Clutch type (dry wet single, multiple disc)	Dry Plate Single Disc	
Linkage (hydraulic cable rod lever other)	Cable with Self-Adjustment	
Max pedal effort (nom sprng load) N (lbs)	Depressed	130 (30)
	Released	111 (25)
Assist (sprng, power/percent nominal)	No	
Type pressure plate sprngs	Belleville Sprngs	
Total sprng load (nominal) N (lbs)	7000 (1573)	
Clutch facing	Facing mfg & material coding	Valeo F-202
	Facing material & construction	Woven Non-Asbestos
	Rivets per facing	8
	Outside x inside dia (nominal)	280 x 198 (11 02 x 7 8)
	Total eff area cm <sup>2</sup> (in <sup>2</sup> )	307 8 (47 6)
	Thickness (pressure plate side/fly wheel side)	3 35 (0 132) / 3 35 (0 132)
	Rivet depth (pressure plate side/fly wheel side)	1 2 (0 047) / 1 2 (0 047) Minimum
	Engagement cushion method	Segmented
Release bearing type & method lub	Self-Centering, Angular Contact, Constant Running, Prepacked	
Torsional damping method sprngs hysteresis	Multi-State, Springs and Friction Material	

\* Includes shift linkage lubricant and clutch housing if other specify

# Specifications

Vehicle Line MUSTANG  
 Model Year 2002 Issued 10/02 Revised (\*) \_\_\_\_\_

## METRIC

Engine Description  
 Engine Code

**4 6L (SOHC)  
 GT MODELS**

### Transmissions/Transaxle (Std , Opt , N A )

Manual 4 speed (manufacturer/country)	N / A
Manual 5 speed (manufacturer/country)	Standard (Tremec / Mexico)
Manual 6 speed (manufacturer/country)	N / A
Automatic (manufacturer/country)	N / A
Automatic overdrive (manufacturer/country)	Optional (Ford / USA)

### Manual Transmission/Transaxle

Number of forward speeds	Five	
Gear ratios	1st	3 37
	2nd	1 99
	3rd	1 33
	4th	1 00
	5th	0 67
	6th	—
	Reverse	3 22
Synchronous meshing (specify gears)	All Forward Gears	
Shift lever location	Floor	
Trans case matl & mass kg (lbs)*	Aluminum and 50 (110)	
Lubricant	Capacity L (pt )	3 1 (6 6)
	Type recommended	Dexron III

### Clutch (Manual Transmission)

Clutch manufacturer	Valeo	
Clutch type (dry wet single multiple disc)	Dry Plate, Single Disc	
Linkage (hydraulic cable rod lever other)	Cable with Self-Adjustment	
Max pedal effort (nom spring load) N (lbs)	Depressed	125 (28)
	Released	148 (33)
Assist (spring power/percent nominal)	No	
Type pressure plate springs	Belleville Springs	
Total spring load (nominal) N (lbs)	8795 (1977)	
Clutch facing	Facing mtr & material coding	Valeo F-202
	Facing material & construction	Woven Non-Asbestos
	Rivets per facing	9
	Outside x inside dia (nominal)	268 x 170 (10 55 x 6 69)
	Total eff area cm <sup>2</sup> (in <sup>2</sup> )	337 (52 25)
	Thickness (pressure plate side/fly wheel side)	3 6 (0 14) / 3 6 (0 14)
	Rivet depth (pressure plate side/fly wheel side)	1 4 (0 055) / 1 4 (0 055)
	Engagement cushion method	Segmented
Release bearing type & method lub	Self-Centering, Angular Contact, Constant Running, Prepacked	
Torsional damping method springs hysteresis	Single-Stage, Springs and Friction Material	

\* Includes shift linkage lubricant and clutch housing. If other specify

# Specifications

Vehicle Line MUSTANG  
 Model Year 2002 Issued 10/02 Revised (\*) \_\_\_\_\_

## METRIC

Engine Description  
 Engine Code

<b>3 8L</b>	<b>4 6L (SOHC)</b>
<b>3 27 1 AXLE</b>	<b>3 27 1 AXLE</b>

### Automatic Transmission/Transaxle

Trade Name	Automatic Overdrive, Electronic Wide Ratio -- (4R70W)		
Type and special features (describe)	4-Speed Electronically Controlled Torque Converter Lock-up and Shift Pattern, Planetary Gear Set		
Shift mechanics	Non-Synchronous 1 to 2 / 2 to 3 Synchronous 3 to 4		
Gear selector	Location (column floor other)	Floor (O/D Push Button Lockout Switch Located in Console)	
	Ltr./No designation (e.g. PRND21)	P R N D 2 1	
	Shift interlock (yes no describe)	Yes Locks Selector in "PARK" Position until Service Brakes are Applied	
Gear ratios	1st	2 84	
	2nd	1 55	
	3rd	1 00	
	4th	0 70	
	Reverse	2 32	
	Final drive ratio	2 29 1	2 29 1
Max upshift vehicle speed drive range km/h (mph)	(a)	(b)	
Max upshift engine speed RPM	5200	6000	
Max kickdown speed - drive range km / h (mph)	161 (100) 4-3	169 (105) 4-3	
	108 (67) 3-2	117 (73) 3-2	
Min overdrive speed km / h (mph)	62 (39) 3-4	51 (32) 3-4	
	Type	Piston Plate Modulated Lock-Up Converter	
Torque converter	Torus design	Full	
	Number of elements	Three	
	Max ratio at stall	2 4	
	Type of cooling (air liquid)	Liquid	
	Nominal diameter	305 (12)	286 (11 25)
	Capacity factor "K"	163 (140)	180 (155)
Pump type	Gerotor		
Lubricant	Capacity refill L (pt)	13 1 (27 8)	12 (25 6)
	Type recommended	WSS-M2C202-B (Mercon® V for Service)	
Oil cooler (std opt , N A internal external air liquid)	Standard, External Oil to Engine Coolant		
Transmission mass kg (lbs) & case material**	90 9 (200 4), Aluminum	88 8 (195 8)	

### All Wheel / 4 Wheel Drive

(NOT OFFERED)

Description & type (part time full time 2/4 shift while moving mechanical elect cham/gear etc)		
Transfer case	Manufacturer and model	
	Type and location	
Low-range gear ratio		
System disconnect (describe)		
Center differential	Type (bevel planetary, w or w/o viscous bias torsen etc)	
	Torque split (% front/rear)	

\* Input speed - square root of torque

\*\* Dry weight including torque converter // other specify

(a) 66 (41) 1 2 124 (77) 2 3 175 (109) 3-4 3 8L

(b) 71 (44) 1 2, 126 (78) 2 3 185 (115) 3-4 4 6L



# Specifications

Vehicle Line MUSTANG  
 Model Year 2002 Issued 10/02 Revised (\*) \_\_\_\_\_

## METRIC

Engine Description  
 Engine Code

3 8L

4 6L (SOHC)

### Axle Ratio and Tooth Combinations (See 'Power Teams' for axle ratio usage)

Axle ratio (or overall top gear ratio)	3 27 1	
Ring gear o d	223 5 (8 8)	
No of teeth	Pinion	11
	Ring gear	36

### Rear Axle Unit

(Regular Axle)

(Traction-Lok Axle)

Description	Semi-Floating Type with Cast Center and Underhung Pinion		
Limited slip differential (type)	N / A	Frction Plate	
Drive Pinion	Type	Hypoid	
	Offset	25 4 (1 0)	38 1 (1 5)
No of differential pinions	Two		
Pinion / differential	Adjustment (shim etc)	Shim	
	Bearing adjustment	Collapsible Spacer, Shim	
Driving wheel bearing (type)	Straight Roller		
Lubncant	Capacity L (pt)	1 6 (3 5)	1 9 (4 25)
	Type recommended	WSP-M2C 197-A, SAE 80 W 90 GL-5	WSP-M2C 197-A SAE 80 W 90 GL 5 (a)

(a) Add 4 oz M2C 118-A Frction Modifier

### Propeller Shaft — Rear Wheel Drive

Manufacturer

Type (straight tube tube in tube  
 internal external damper etc)

Ford Straight Tube with Internal Tuned Damper

Outer diam x length* x wall thickness	Manual 4-speed transmission	N / A	
	Manual 5-speed transmission	88 9 x 1163 x 1 65 (3 50 x 45 6 x 065)	88 9 x 1153 x 1 65 (3 50 x 45 4 x 065)
	Manual 6 speed transmission	N / A	
	Overdrive	N / A	
	Automatic Transmission 4 Speed AODE	88 9 x 1163 x 1 65 (3 50 x 45 6 x 065)	88 9 x 1153 x 1 65 (3 50 x 45 4 x 065)
Intermediate bearing	Type (plain anti frction)	N / A	
	Lubncation (fitting, prepack)	N / A	
Slip yoke	Type	Damper	Plain w/ MT Damper w/ AT
	Number of teeth	28	31
	Spline o d	38 05 (1 498)	
Make and mtg no	Front	Ford 1330	
	Rear	Ford 1330	
Number used	Two		
Universal joints	Type (ball and trunnion cross)	Cross	
	Rear attach (u bolt clamp etc)	Circular Flange	
	Bearing	Type (plain anti frction)	Needle Roller
Lubncation (fitting prepack)		Pre-pack	
Drive taken through (torque tube arms or springs)	Control Arms		
Torque taken through (torque tube arms or springs)	Control Arms		

Centerline to centerline of universal joints or to centerline of rear attachment

# Specifications

Vehicle Line MUSTANG  
 Model Year 2002 Issued 10/02 Revised (\*) \_\_\_\_\_

## METRIC

Model Code/Description And/Or  
 Engine Code/Description

**MUSTANG V-6**

### Suspension – General Including Electronic Controls (SEE PAGE 11A FOR GT)

Car leveling	Standard/optional/not avail	N / A	
	Manual/automatic control	—	
	Type (air/hydraulic)	—	
	Primary/assist spring	—	
	Rear only/4 wheel leveling	—	
	Single/dual rate spring	—	
	Single/dual ride heights	—	
	Provision for jacking	—	
Shock absorber damping controls	Standard/option/not avail	N / A	
	Manual/automatic control	—	
	Number of damping rates	—	
	Type of actuation (manual/ electric motor/air etc )	—	
	s e n s o r s	Lateral acceleration	—
		Deceleration	—
		Acceleration	—
		Road surface	—
Shock absorber (front & rear)	Type	Strut — Front / Shock — Rear, Gas-Pressurized Hydraulic	
	Make	Monroe Automotive	
	Piston diameter	Front 32 (1 26) / Rear 30 12 (1 19)	
	Rod diameter	Front 22 (0 87) / Rear 12 5 (0 5)	

### Suspension – Front

Type and description	Hybrid MacPherson Strut with Spring Mounted on Lower Control Arm	
Travel	Full bounce (define load condition)	70 4 (2 77)
	Full rebound	101 2 (3 98)
Spring	Type (coil leaf other & material)	Coil, SAE-5160-H Steel
	Insulators (type & material)	Upper-Ring, Lower-Sleeve & Rubber
	Size (Leaf length & width Coil design height & i d Bar length & diameter)	254 (10 0) and 89 0 (3 50)
	Spring rate [N/mm (lb/in )]	78 8 (450)
Stabilizer	Rate at wheel [N/mm (lb/in )]	21 0 (119)
	Type (link linkless frameless)	Link, Bayonet-Style with Polyurethane Bushings
	Material & O D bar/tube wall thickness	SAE-J403-1090 Solid Bar, 25 4 (1 00) with Self-Lubricating Elastomer Insulator

### Suspension – Rear

Type and description	Four Bar Link with Coil Spring on Lower Arm	
Travel	Full bounce (define load condition)	64 9 (2 55)
	Full rebound	122 4 (4 82)
Spring	Type (coil leaf other & material)	Coil, SAE-5160-H Steel
	Size (Leaf length & width Coil design height & i d Bar length & diameter)	220 (8 7) and 102 (4 02)
	Spring rate [N/mm (lb/in )]	36 8 (210)
	Rate at wheel [N/mm (lb/in )]	17 9 (102 7)
	Insulators (type & material)	Upper Disc (Rubber), Lower Disc (Rubber)
	leaf	No of leaves
Shackle (comp or tens)		N / A
Stabilizer	Type (link, linkless frameless)	N / A
	Material & O D bar/tube wall thickness	
Track bar (type)	None	

# Specifications

Vehicle Line MUSTANG  
 Model Year 2002 Issued 10/02 Revised (+) \_\_\_\_\_

## METRIC

Model Code/Description And/Or  
 Engine Code/Description

### MUSTANG GT MODELS

#### Suspension – General Including Electronic Controls

Car leveling	Standard/optional/not avail	N / A	
	Manual/automatic control	—	
	Type (air/hydraulic)	—	
	Primary/assist spring	—	
	Rear only/4 wheel leveling	—	
	Single/dual rate spring	—	
	Single/dual ride heights	—	
	Provision for jacking	—	
Shock absorber damping controls	Standard/option/not avail	N / A	
	Manual/automatic control	—	
	Number of damping rates	—	
	Type of actuation (manual/ electric motor/air, etc )	—	
	S e n s o r s	Lateral acceleration	—
		Deceleration	—
		Acceleration	—
		Road surface	—
Shock absorber (front & rear)	Type	Front Struts / Vert Rear Shocks, Gas-Pressurized Hydraulic, Horizontal Rear Dampers	
	Make	Front Struts / Rear Shocks — Monroe Automotive, Rear Dampers — Arvin	
	Piston diameter	Front 32 (1 26) / Rear 30 12 (1 19), Damper 25 4 (1 00)	
	Rod diameter	Front 22 (0 87) / Rear 12 5 (0 5), Damper 12 5 (0 50)	

#### Suspension – Front

Type and description	Hybrid MacPherson Strut with Spring Mounted on Lower Control Arm	
Travel	Full jounce (define load condition)	70 4 (2 77)
	Full rebound	101 2 (3 98)
Spring	Type (coil leaf other & material)	Coil, SAE 5160 Steel
	Insulators (type & material)	Upper — Ring, Lower — Sleeve and Rubber
	Size (Leaf length & width Coil design height & i d Bar length & diameter)	254 (10 0) and 89 0 (3 5)
	Spring rate [N/mm (lb./in.)]	78 8 (450)
	Rate at wheel [N/mm (lb./in.)]	21 0 (119)
Stabilizer	Type (link linkless frameless)	Link, Bayonet-Style with Polyurethane Bushings
	Material & O D bar/tube wall thickness	SAE-J403-1090 Solid Bar, 26 5 (1 04) with Self-Lubricating Elastomer Insulator

#### Suspension – Rear

Type and description	Four Bar Link with Coil Spring on Lower Arm, Also includes both Vertical Shock Absorbers and Horizontal Axle Dampers		
Travel	Full jounce (define load condition)	64 9 (2 55)	
	Full rebound	122 4 (4 82)	
Spring	Type (coil leaf other & material)	Coil and SAE 5160H Steel	
	Size (Leaf length & width Coil design height & i d Bar length & diameter)	220 (8 7) & 102 (4 02)	
	Spring rate [N/mm (lb./in.)]	36 8 (210)	
	Rate at wheel [N/mm (lb./in.)]	17 9 (102 7)	
	Insulators (type & material)	Lower Disc (Rubber) and Upper Disc (Rubber)	
	If leaf	No of leaves	N / A
		Shackle (comp or tens)	N / A
Stabilizer	Type (link linkless frameless)	Linkless	
	Material & O D bar/tube wall thickness	SAE-J403, 5160 Solid Bar, 23 0 (0 90)	
Track bar (type)	None		

# Specifications

Vehicle Line MUSTANG  
 Model Year 2002 Issued 10/02 Revised (\*) \_\_\_\_\_

## METRIC

Model Code/Description And/Or  
 Engine Code/Description

<b>MUSTANG STANDARD/ DELUXE/PREMIUM MODELS</b>	<b>MUSTANG GT MODELS</b>
--	--------------------------

### Brakes — Service

Description		Four Wheel Hydraulic Actuated System		
Manufacturer and brake type (std opt n a)	Front (disc or drum)	Disc		
	Rear (disc or drum)	Disc		
Valving type (proportion delay, metering other)		Proportion (700 / 0 43)		
Power brake (std opt , n a)		Standard		
Booster type (remote integral vac hyd etc)		205 (8 07) Tandem Vacuum	Hydraulic	
Vacuum	Source (inline pump etc)	Inline		
	Reservoir (volume in <sup>3</sup> )	N / A		
	Pump-type (elec gear driven belt driven)	N / A		
Traction assist	Operational speed range	Full Speed		
	Type (engine or brake intervention)	Opt (Std w/Premium) / Engine	Std / Engine	
Anti lock device	Front / rear (std opt n a)	Opt / Opt	Std / Std	
	Manufacturer	Bosch		
	Type (electronic mech)	Electronic		
	Number sensors or circuits	4		
	Number anti-lock hydraulic circuits	4 with ABS / TC	4	
	Integral or add-on system	Integral		
	Yaw control (yes no)	No		
Hydraulic power source (elec vac mtr pwr strg)		Vacuum	Power Steering Pump	
Effective area cm <sup>2</sup> (in <sup>2</sup> )*		222 / 102		
Gross Lining area cm <sup>2</sup> (in <sup>2</sup> )**(F/R)		238 / 107 (16 6)		
Swept area cm <sup>2</sup> (in <sup>2</sup> ***)(F/R)		1486 / 1086 (168 3)		
Rotor	Outer working diameter	F/R	276 (10 8) / 266 (10 5)	
	Inner working diameter	F/R	175 7 (6 9) / 180 5 (7 1)	
	Thickness	F/R	26 (1 02) / 14 (0 55)	
	Material & type (vented/solid)	F/R	Cast Iron, Vented / Cast Iron, Solid	
Drum	Diameter & width	F/R	N / A	
	Type and material	F/R	—	
Wheel cylinder bore		43 0 (1 7) – 2 Cal Front / 38 0 (1 6) – Rear	40 5 (1 6) – 2 Cal Front / 38 0 (1 5) – Rear	
Master cylinder	Bore/stroke	F/R	25 4 (1 0) / 25 08 (0 99) (a)	
Pedal arc ratio		3 5 1		
Line pressure at 445 N(100 lb )pedal load [kPa (psi)]		8881 (1288)		
Lining clearance		F/R		
Brake lining	Front wheel	Bonded or riveted (rivets/seg)	Bonded	
		Rivet size	N / A	
		Manufacturer	Akebono	
		Lining code*****	AK-NS187H	
		Material	Low Metallic, Non Asbestos	
		**** Primary or out board	130 x 52 x 9 5 (5 1 x 2 1 x 0 4)	
		Size Secondary or in board	130 x 52 x 9 5 (5 1 x 2 1 x 0 4)	
	Shoe thickness (no lining)	6 0 (0 23)		
	Rear wheel	Bonded or riveted (rivets/seg)	Bonded	
		Manufacturer	Akebono	
		Lining code*****	AK-NS516H	
		Material	Low Metallic, Non Asbestos	
		**** Primary or out-board	72 4 x 38 x 12 (2 8 x 1 5 x 0 47)	72 4 x 38 x 10 (2 8 x 1 5 x 0 40)
		Size Secondary or in board	72 4 x 38 x 12 (2 8 x 1 5 x 0 47)	72 4 x 38 x 10 (2 8 x 1 5 x 0 40)
Shoe thickness (no lining)		5 0 ( 20)		

\* Excludes rivet holes grooves chamfers etc \*\*Includes rivet holes grooves chamfers etc  
 \*\*\* Total swept area for four brakes (Drum brake Widest lining contact width for each brake x its contact circumference )  
 (Disc brake Square of Outer Working Dia minus Square of inner Working Dia multiplied by Pi/2 for each brake )  
 \*\*\*\* Size for drum brakes includes length x width x thickness \*\*\*\*\*Manufacturer I D catalog for formulation designation and coefficient of friction classification  
 (a) 25 4 (1 0) / 37 27 (1 30) 3 8L w/Traction Control

# Specifications

Vehicle Line MUSTANG  
 Model Year 2002 Issued 10/02 Revised (\*) \_\_\_\_\_

## METRIC

Model Code/Description And/Or  
 Engine Code/Description

**MUSTANG MODELS**

**MUSTANG GT MODELS**

### Tires And Wheels (Standard)

Tires	Size (service description)		P225/55R16 94T	245/45ZR17	
	Type (bias radial steel nylon etc)		Steel Belted Radial		
	Inflation pressure (cold) for recommended max vehicle load	Front kPa (psi)	240 (35)	207 (30)	
		Rear kPa (psi)	240 (35)	207 (30)	
Rev /mile at 70 km/h (45 mph)		812	814		
Wheels	Type & material		Aluminum, 5-Spoke, Painted (a)	Aluminum, 5-Spoke Painted (b)	
	Rim (size & flange type)		16" x 7.5" J	17" x 8.0" J	
	Wheel offset		30.0 (1.18)		
	Attachment	Type (bolt or stud & nut)	Stud		
		Circle diameter	(4.5)		
Number & size		Five - 12.7 (50) - 20 Thd			
Spare	Tire and wheel		T145/80D16, 415 kPa (60 PSI), Steel Wheel (16" x 4.5"), Temporal Spare (High Pressure) (Aluminum Wheel Optional on Some Models) (c)		
	Storage position & location (describe)		Flat Position, Deep Well in Trunk		

### Tires and Wheels (Optional)

Tire size (service description)	
Type (bias radial steel nylon etc)	
Wheel (type & material)	
Rim (size flange type and offset)	
Tire size (service description)	
Type (bias radial, steel nylon etc)	
Wheel (type & material)	
Rim (size flange type and offset)	
Tire size (service description)	
Type (bias radial steel nylon etc)	
Wheel (type & material)	
Rim (size flange type and offset)	
Tire size (service description)	
Type (bias radial steel nylon etc)	
Wheel (type & material)	
Rim (size flange type and offset)	
Spare tire and wheel size (if configuration is different than road tire or wheel describe optional spare tire and/or wheel location & storage position)	

### Brakes — Parking

Type of control	Pull Level - Push Button Release	
Location of control	Tunnel Mounted	
Operates on	Rear Service Brakes	
If separate from service brakes	Type (internal or external)	N / A
	Drum diameter	—
	Lining size (length x width x thickness)	—

(a) Bought with Premium Coupe Deluxe/Premium Convertible and Optional Sport Package  
 (b) Includes Bought Flange on GT Premium Models  
 (c) T155/70R17 415 kPa (60 PSI), 17" x 4" Wheel Temporal Spare (High Pressure) on GT Models

# Specifications

Vehicle Line MUSTANG  
 Model Year 2002 Issued 10/02 Revised (\*) \_\_\_\_\_

## METRIC

Model Code/Description And/Or  
 Engine Code/Description

**MUSTANG MODELS**

**MUSTANG GT MODELS**

### Steering

Manual (std opt n a)		N / A					
Power (std opt n a)		Standard					
Speed-sensitive (std opt n a)		N / A					
4-wheel steering (std opt , n a)		N / A					
Adjustable steering wheel/column (tilt telescope, other)	Type	Tilt Column					
	Manufacturer	Ford					
	(std , opt n a)	Standard					
Wheel diameter** (W9) SAE J1100	Manual	N / A					
	Power	Std 381 (15)					
Turning diameter m (ft)	Outside front	Wall to wall (l & r)					
		Curb to curb (l & r)	11 6 (38 1)				
	Inside rear	Wall to wall (l & r)					
		Curb to curb (l & r)					
Scrub Radius*		13 3	5 5				
Manual	Gear	Type	N / A				
		Manufacturer	—				
		Ratios	<table border="1"> <tr> <td>Gear</td> <td>—</td> </tr> <tr> <td>Overall</td> <td>—</td> </tr> </table>	Gear	—	Overall	—
	Gear	—					
	Overall	—					
No wheel turns (stop to stop)		—					
Type (coaxial, elec hyd etc)		Integral Hydraulic					
Manufacturer		Gear (Ford), Pump (Ford), Fluid WSA-M2C195-A					
Power	Gear	Type	Rack and Pinion				
		Ratios	<table border="1"> <tr> <td>Gear</td> <td>6 44*/mm Constant Ratio</td> </tr> <tr> <td>Overall</td> <td>15 0 1 on Center, 13 2 1 at Stops</td> </tr> </table>	Gear	6 44*/mm Constant Ratio	Overall	15 0 1 on Center, 13 2 1 at Stops
		Gear	6 44*/mm Constant Ratio				
	Overall	15 0 1 on Center, 13 2 1 at Stops					
	Pump (drive)		Multi-Rib Belt Off Crankshaft Pulley				
No wheel turns (stop to stop)		2 74	2 62				
Type		Rack and Pinion (Rod and Ball Joint Directly Attached to Gear)					
Linkage	Location (front or rear of wheels other)	Front of Wheels					
	Tie rods (one or two)	Two (Integral with Gear)					
Steering axis	Inclination at camber (deg)		17 7°				
	Bearings (type)	Upper	Strut Mount				
		Lower	Ball Joint				
		Thrust					
Steering spindle/knuckle & joint type		Forged Spindle, with Ball Joint					

\* The horizontal distance in the front elevation between wheel centerline and kingpin (ball joint) axis at ground

\*\* See Page 23

# Specifications

Vehicle Line MUSTANG

Model Year 2002 Issued 10/02 Revised \_\_\_\_\_

## METRIC

Model Code/Description And/Or  
Engine Code/Description

### MUSTANG AND GT MODELS

#### Wheel Alignment

Front wheel at curb mass (wt)	Service checking	Caster (deg)	$+3.2^{\circ} \pm 0.75^{\circ}$ (a)
		Camber (deg)	$-0.6^{\circ} \pm 0.5^{\circ}$ (a)
		Toe in outside track mm (in) (deg)	$0.125^{\circ} \pm 0.075^{\circ}$ (Nominal - $0.25^{\circ} \pm 0.15^{\circ}$ ) (b)
	Service reset*	Caster (deg)	Factory Set and Cannot Be Adjusted
		Camber (deg)	$-0.6^{\circ} \pm 0.5^{\circ}$ (a)
		Toe in mm (in) (deg)	$0.125^{\circ} \pm 0.075^{\circ}$ (Nominal - $0.25^{\circ} \pm 0.15^{\circ}$ )
	Periodic M V inspection	Caster (deg)	$+3.2^{\circ} \pm 0.75^{\circ}$ (a)
		Camber (deg)	$-0.6^{\circ} \pm 0.5^{\circ}$ (a)
		Toe-in - mm (in) (deg)	$0.125^{\circ} \pm 0.075^{\circ}$ (Nominal - $0.25^{\circ} \pm 0.15^{\circ}$ )
Rear wheel at curb mass (wt)	Service checking	Camber (deg)	N / A
		Toe in outside track-mm (in)	N / A
	Service reset*	Camber (deg)	N / A
		Toe in mm (in)	N / A
	Periodic M V inspection	Camber (deg)	N / A
		Toe in mm (in)	

\* Indicates pre-set adjustable trend set or other

(a) Max Side-to-Side Difference Not to Exceed  $\pm 0.75^{\circ}$

(b) Steering Wheel Must be Within  $\pm 2^{\circ} \pm 3^{\circ}$  (Counter-Clockwise) After Toe Setting

#### Electrical - Instruments and Equipment

Speedometer	Type (analog, digital std opt)	Analog, Standard 193 KPH / 120 MPH (c)
	Trip odometer (std opt n a)	Standard / Vacuum Fluorescent (V F)
	Standard optional not available	N / A
Head up display	Type	Secondary opto electronic
	Speedometer	Digital
	Status/warning indicators	Turn signals high beam low fuel check gauges
	Brightness control	Day / night mode adjustable
	EGR maintenance indicator	
Charge indicator	Type	90° Magnetic Voltmeter Gauge, Standard
	Warning device (light audible)	Warning Light, Standard
Temperature indicator	Type	90° Magnetic Gauge, Standard
	Warning device (light audible)	N / A
Oil pressure indicator	Type	90° Magnetic Gauge, Standard
	Warning device (light audible)	N / A
Fuel indicator	Type	90° Magnetic Gauge, Standard
	Warning device (light audible)	Low Fuel Warning
Wind shield wiper	Type (standard)	Two Speed Electric Column-Mounted Control, Interval Wipe, Standard
	Type (optional)	N / A
	Blade length	500 (20)
	Swept area cm <sup>2</sup> (in <sup>2</sup> )	6381 (989)
Wind shield washer	Type (standard)	Electric Pump (Impeller Type Dual Fluidic Spray), Standard
	Type (optional)	N / A
	Fluid level indicator (light audible)	N / A
Rear window wiper wiper/washer (std opt n a)		N / A
Horn	Type	Air Electric
	Number used	Two Standard — One Hi-Pitch, One Lo-Pitch
Other		See Page 15A

(c) 241 KPH / 150 MPH with GT Model

# Specifications

Vehicle Line MUSTANG  
Model Year 2002 Issued 10/02 Revised (\*) \_\_\_\_\_

## METRIC

### SUPPLEMENTAL PAGE

---

#### Electrical Instruments and Equipment (Cont'd)

- Brake System Warning Light
- Emergency Flashers
- Directional Turn Signal Lights
- Hi-Beam Indicator Light
- Fasten Seat Belts Warning Light
- Headlamps "ON" Reminder Chime, Safety Belt Warning Chime, Ignition Key Reminder Chime
- Check Engine Warning Light (Emissions Warning)
- Air Bag Readiness Light
- Anti-Lock Brake System, Warning Light
- Overdrive "Off" Indicator Light
- Low Fuel Warning Light
- Loose Fuel Cap Light



# Specifications

Vehicle Line MUSTANG  
 Model Year 2002 Issued 10/02 Revised (-) \_\_\_\_\_

## METRIC

Model Code/Description

**MUSTANG MODELS / 3 8L**

### Electrical – Supply System

Battery	Manufacturer	Johnson Controls Inc
	Model (std opt )	Standard
	Voltage	12
	Amps at 0°F cold crank	540
	Minutes reserve capacity	100
	Amps/hrs 20 hr rate	58
	Location	Left-Hand Front of Engine Compartment
Alternator	Manufacturer	Visteon (Rawsonville)
	Rating (idle/max rpm)	57/110 Amp / Max (1R3U-10300-AD)
	Ratio (alt crank/rev )	2 79 1
	Output at idle (rpm park)	64 Amps
	Optional (type & rating)	N / A
Regulator	Type	Electronic – Integral with Alternator

### Electrical – Starting System

Motor	Manufacturer	Visteon (Ypsilanti) – Permanent Magnet Type
	Current drain 20 (°F)	300 – 400 Amps
	Power rating kw (hp)	1 4 (1 9)
Motor drive	Engagement type	Positive (F7SU-A1B)
	Pinion engages from (front rear)	Front, Conventional Axial Mount

### Electrical – Ignition System

Type	Electronic (std opt n a )	Standard	
	Other (specify)	Integral EDIS	
Coil	Manufacturer	Motorcraft (Visteon Ypsilanti)	
	Model	6 Tower DIS Ignition Coil 1F2U-12029-AC	
	Current	Engine stopped – A	0 Amps
		Engine idling – A	Peak 6 75 Amps
Spark plug	Manufacturer	Motorcraft (Allied Signal)	
	Model	AGSF-42-EGM – RH Bank AGSF-42-EG – LH Bank (For Service AWSF 42-EEM)	
	Thread (mm)	14	
	Tightening torque N•m (lb ft)	9 – 20 (7 – 15)	
	Gap	1 32 – 1 42 ( 052 – 056)	
	Number per cylinder	One	
Distributor	Manufacturer	N / A	
	Model	N / A	

### Electrical – Suppression

Locations & type	Capacitor in Alternator Resistor Spark Plugs and Resistance Core Ignition Wire Ground Cable – Engine to Dash Ground Cable, Hood Bond, RF Shielding Material
------------------	---

# Specifications

Vehicle Line MUSTANG  
 Model Year 2002 Issued 10/02 Revised (\*) \_\_\_\_\_

## METRIC

Engine Code/Description

**MUSTANG GT 4 6L (SOHC)**

### Electrical – Supply System

Battery	Manufacturer	Johnson Controls Inc
	Model (std opt)	Standard
	Voltage	12
	Amps at 0°F cold crank	540
	Minutes reserve capacity	100
	Amps/hrs 20 hr rate	58
	Location	Left Front of Engine Compartment
Alternator	Manufacturer	Visteon (Rawsonville)
	Rating (idle/max rpm)	65/110 Amp / Max (XR3U-AC)
	Ratio (alt crank/rev)	3 16 1
	Output at idle (rpm, park)	65 Amps
	Optional (type & rating)	N / A
Regulator	Type	Electronic Integral with Alternator

### Electrical – Starting System

Motor	Manufacturer	Visteon (Ypsilant) – Permanent Magnet Type
	Current drain _____ (°F)	300 – 400
	Power rating kw (hp)	1.4 (1.9)
Motor drive	Engagement type	Positive (F7UU-AB)
	Pinion engages from (front rear)	Front

### Electrical – Ignition System

Type	Electronic (std opt n a)	Standard, Electronic Distributorless Ignition System (EDIS)	
	Other (specify)	N / A	
Coil	Manufacturer	Visteon	
	Model	COP 1F2U-12A366-AA	
	Current	Engine stopped – A	0 Amps
		Engine idling – A	Less Than 6.5 Amps
Spark plug	Manufacturer	Honeywell	
	Model	AWSF-32P	
	Thread (mm)	14	
	Tightening torque N*m (lb-ft)	9 – 20 (7 – 15)	
	Gap	1.37 (0.54)	
Distributor	Number per cylinder	One	
	Manufacturer	N / A	
	Model	N / A	

### Electrical – Suppression

Locations & type : Capacitor in Alternator, Resistor Spark Plugs, Resistance Ignition Wire Ground Cable – Engine to Dash, Hood Bond Ignition Coil Capacitor

# Specifications

Vehicle Line MUSTANG  
 Model Year 2002 Issued 10/02 Revised (\*) \_\_\_\_\_

## METRIC

Model Code/Description

**ALL MODELS**

## Body

Structure	Unitized All-Steel Welded Body with Multi-Piece Side Stampings and Energy-Absorbing Front and Rear Structures
Bumper system front - rear	Impact-Resistant TPO Fascias with Ultra High Strength Steel Understructure at Front and Rear Front/Rear - 5 MPH Bumpers - Ford Requirements
Anti corrosion treatment	<ul style="list-style-type: none"> <li>• Major Exterior and Underbody Sheet Metal Components and Panels Pre-Coated (Galvanized) Steel</li> <li>• Body Cathodically Electrocoat Primed</li> <li>• Urethane Chip-Resistant Primer</li> <li>• Grille Integral with Polyurethane Fascia</li> </ul>

## Body - Miscellaneous Information

Type of finish (lacquer enamel other)	Enamel Acrylic (All Colors Clearcoat Except White)	
Hood	Material & mass	Composite (SMC), 15 (33)
	Hinge location (front rear)	Rear
	Type (counterbalance prop)	Prop
	Release control (internal external)	Primary - Internal, Secondary - External
Trunk lid	Material & mass	SMC, 12 2 (26 83), 3 8L 15 3 (33 58) GT
	Type (counterbalance other)	Counterbalance - Gas Spring
	Internal release control (elec mech n a)	Electric (with Power Lock Group)
Hatch back lid	Material & mass	N / A
	Type (counterbalance other)	--
Tailgate	Material & mass	N / A
	Type (drop lift door)	--
Vent window control (crank friction pivot power)	Internal release control (elec mech n a)	--
	Front	N / A
Window regulator type (cable tape flex drive etc)	Rear	N / A
	Front	Mechanical Drive (Cross Arm)
Seat cushion type (e.g. 60/40 bucket bench wire foam etc)	Rear	N / A Except Convertible Convertible - Mechanical Drive (Single Arm)
	3rd seat	Bucket, Stamped Frame - Coil Springs and Flexolator-Foam Pad (a)
	None	Bench Integral Frame and Foam Pad Assembly
Seat back type (e.g. 60/40 bucket bench wire foam etc)	Front	Bucket, Stamped Frame - Foam Pad (a)
	Rear	Bench Frm Hdbrd with Foam Pad Assy on Convertible (Fold Down Split 50/50 for Coupe)
	3rd seat	None

## Frame

Type and description (separate frame unitized frame partially unitized frame) : Unitized Construction

(a) Articulated Front Sport Seats Standard with GT

# Specifications

Vehicle Line MUSTANG  
 Model Year 2002 Issued 10/02 Revised (\*) \_\_\_\_\_

## METRIC

Model Code/Description

**ALL MODELS**

## Restraint System

Seating Position		Left	Center	Right	
Active	Type & description (lap & shoulder belt lap belt etc)	First seat	Type 2 3-Point Lap and Shoulder Belt Standard	N / A	Type 2 3 Point Lap and Shoulder Belt Standard
		Second seat	Type 2 3-Point Lap and Shoulder Belt Standard	N / A	Type 2 3-Point Lap and Shoulder Belt Standard
	Standard / optional	Third seat	N / A	N / A	N / A
Passive	Type & description (air bag motorized 2 point belt fixed belt knee bolster manual lap belt)	First seat	Frontal Air Bag	N / A	Frontal Air Bag
		Second seat	N / A	N / A	N / A
	Standard / optional	Third seat	N / A	N / A	N / A

Glass	SAE Ref No	2-DOOR COUPE	CONVERTIBLE
Windshield glass exposed surface area cm <sup>2</sup> (in <sup>2</sup> )	S1	10072 3 (1611 2)	
Side glass exposed surface area cm <sup>2</sup> (in <sup>2</sup> ) - total 2-sides	S2	1704 5 (264 2) Quarter Window 8221 54 (1274 34) Total	7684 78 (1191 14) Total
Backlight glass exposed surface area cm <sup>2</sup> (in <sup>2</sup> )	S3	10117 8 (1618 8)	
Total glass exposed surface area cm <sup>2</sup> (in <sup>2</sup> )	S4	28411 6 (4403 8)	
Windshield glass (type/thickness)		Laminated / 5 1 (0 2)	
Side glass (type/thickness)		Tempered / 4 7 (0 19) Door 3 2 (0 126) Quarter	Tempered / 4 7 (0 19) Door 4 7 (0 19) Quarter
Backlight glass (type/thickness)		Tempered / 3 4 (0 134)	
Tinted (yes/no location)		Yes	
Solar control (yes/no, coated/batched location)		Running Change 1999 Model Year	

## Headlamps

**ALL MODELS**

Description (sealed beam halogen replaceable bulb etc)	Aero Halogen, Replaceable Bulb (9007)
Shape	Single, Rectangular
Lo beam type (2A1 2B1 2C1 etc)	N / A
Quantity	Two (Combined Two Headlamp System)
Hi beam type (1A1 2A1 1C1 2C1 etc)	N / A
Quantity	Two (Combined Two Headlamp System)

# Specifications

Vehicle Line MUSTANG  
 Model Year 2002 Issued 10/02 Revised (\*) \_\_\_\_\_

## METRIC

Model Code/Description

**MUSTANG AND GT MODELS**

### Climate Control System

Air conditioning (std opt man auto)		Standard, Manual Temperature Control
Condenser	Type	Tube and Fin
	Eff face area (sq mm)	283,870 (440)
	Fins per inch	22
Evaporator	Type	Plate and Fin
	Eff face area (sq mm)	46,452
	Fins per inch	14
Heater core	Material	Aluminum
	Eff face area (sq mm)	28,390
	Fins per inch	26
Compressor	Type	Swashplate
	Displacement (cc)	170
	Manufacturer	Ford
	A/C pulley ratio	1 47 1 with 3 8L 1 44 1 with 4 6L
Accumulator	Type	Domed
	Height (mm)	213
	Diameter (mm)	89
Receiver	Type	N / A
	Height (mm)	—
	Diameter (mm)	—
Refrigerant control (CCOT TVS etc)		CCOT
Heater water valve (yes/no)		No
Refrigerant (R 12 R - 134a etc)		R-134a
Charge level (lbs - oz)		2 lbs -2 oz
Cold engine lockout switch (yes/no)		No
Wide open throttle cutout switch (yes/no)		Yes

# Specifications

Vehicle Line MUSTANG  
 Model Year 2002 Issued 10/02 Revised (\*) \_\_\_\_\_

## METRIC

ALL MODELS

Model Code/Description

### Convenience Equipment (standard, optional, n a )

	Clock (digital analog)	Standard, Digital in Radio
	Compass / thermometer	N / A
	Console (floor overhead)	Standard, Floor
	Defroster electric windshield	N / A
	Defroster electric backlight	Standard
	Diagnostic monitor (integrated individual)	N / A
	Instrument cluster (list instruments)	N / A
	Keyless entry	Standard, Remote Lock, Unlock, Panic, and Trunk
Electronic	Tripminder (avg spd fuel)	N / A
	Voice alert (list items)	N / A
	Other	
	VF Odometer	Standard
	Fuel door lock (remote key electric)	N / A
	Std / opt & location in vehicle	Standard, (LATCH) Accessible Lower Anchors and Top Tether Attachments on Rear Seat
Integrated Child Seating	Number of occupants	—
	Occupant weight/height (min & max )	—
	Restraint system description (3 or 5 point belts/booster seat capability)	—
	Auto head on / off delay, dimming	N / A
	Comenng	N / A
	Courtesy (map reading)	Standard, Combination Dome/Map Light (Integral with Interior Mirror – Convertible)
	Door lock ignition	N / A
	Engine compartment	N / A
Lamps	Fog	Standard on GT Model Not Available on V-6
	Glove compartment	Standard
	Trunk	Standard
	Illuminated entry system (list lamps activation)	Standard (Included with Remote Keyless Entry)
	Other	
	Day / night (auto man)	Standard, Manual (Integral with Map Light on Convertible)
Mirrors	LH (remote power heated)	Standard, Power Remote
	RH (convex remote power heated)	Standard, Convex, Power Remote
	Visor vanity (RH/LH illuminated)	Standard w/Convertible, RH/LH illuminated
	Navigation system (describe)	N / A
	Parking brake auto release (warning light)	N / A

# Specifications

Vehicle Line MUSTANG  
 Model Year 2002 Issued 10/02 Revised (\*) \_\_\_\_\_

## METRIC

Model Code/Description

ALL MODELS

### Convenience Equipment (standard, optional, n a )

	Deck lid (release pull down)	Standard Power Push Button Release	
	Door locks (manual automatic describe system)	Standard Power	
Power equipment	Seats	6 way etc	Optional on V6 and GT, 6-Way Driver's Seat
		Reclining (R H L H)	N / A
		Memory (R H L H preset recline)	N / A
		Support (lumbar)	GT Only, Power Lumbar on Driver (Included with Leather Only)
		Heated (R H L H other)	N / A
	Side windows	Standard Power	
	Vent windows	N / A	
	Rear windows		
Radio systems	Antenna (location whip, w/shield power)	Standard Whip - Right Front Fender	
	Standard	<ul style="list-style-type: none"> <li>Electronic AM/FM Stereo with Cassette, Single Disc CD, Integrated Clock and Premium Sound (80 Watts) on Standard and Deluxe Models (a)</li> <li>MACH 460 Electronic AM/FM Stereo w/In-Dash 6-CD Changer on Premium Models</li> </ul>	
	Optional	<ul style="list-style-type: none"> <li>AM/FM stereo tape compact disc radio prep package etc</li> <li>AM/FM Stereo CD/MP3 w/Clock Optional on Standard and Deluxe Models</li> <li>MACH 460 Electronic AM/FM Stereo w/In-Dash 6-CD Changer Optional on Deluxe Models</li> <li>MACH 1000 Audio System Optional on Premium Models</li> </ul>	
	Speaker (number, location)	Std - Four 5 5" x 7 5", Located in Each Side Door and Package Tray for Coupe, (One in Each Inner Qtr Panel for Convertible), Std Prem Speakers	
	Roof open air or fixed (flip up sliding "T")	N / A	
	Speed control device	Optional	
	Speed warning device (light buzzer etc)	N / A	
	Tachometer (rpm)	7000 on 3.8L, 8000 on GT	
	Telephone system (describe)	N / A	
	Theft deterrent system	Std, SecurLock (PATS) All Models (a) Inc Premium Quality Speakers	

### Trailer Towing

Towing capable	Yes/No	Yes
Engine/transmission/axle	Std/Opt	Standard
Tow class (I II III)*	Std/Opt	Class I
Max gross trailer wgt (lbs)	Std/Opt	1000 / N/A
Max trailer tongue load (lbs)	Std/Opt	100 / N/A
Towing package available	Yes/No	No

\* Class I - 2,000 lbs      Class II - 3,500 lbs      Class III - 5,000 lbs

# Specifications

## METRIC (U.S. Customary)

Vehicle Line MUSTANG

Model Year 2002 Issued 10/02 Revised (\*) \_\_\_\_\_

### Vehicle Dimensions See Key Sheets for definitions

All dimensions to ground are for comparative purposes only. Dimensions are to be shown for all base body models of each vehicle line. SAE Ref. no. refers to the definition published in SAE Recommended Practice J1100 Motor Vehicle Dimensions \* unless otherwise specified.

Model Code/Description	SAE Ref No	COUPE (BASE AND GT)	CONVERTIBLE (BASE AND GT)
<b>Width</b>			
Tread (front)	W101	1530 (60 2), 1518 (59 8) w/GT	1530 (60 2), 1518 (59 8) w/GT
Tread (rear)	W102	1539 (60 6), 1507 (59 3) w/GT	1539 (60 6), 1507 (59 3) w/GT
Vehicle width	W103	1857 (73 1)	
Body width at Sg RP (front)	W117	1758 (69 2)	
Vehicle width (front doors open)	W120		
Vehicle width (rear doors open)	W121		
Tumble-home (degrees)	W122	26 2°	26 3°
Outside mirror width	W410	1963 (77 3)	
<b>Length</b>			
Wheelbase	L101	2572 (101 3)	
Vehicle length	L103	4653 (183 2)	
Overhang (front)	L104	1035 (40 7)	
Overhang (rear)	L105	1046 (41 2)	
Upper structure length	L123	2531 (99 6)	2466 (97 1)
Rear wheel C/L "X" coordinate	L127	4196 (165 2)	
<b>Height*</b>			
Passenger distribution (front/rear)	PD1 2 3, 2 / 2		
Trunk/cargo load		0	
Vehicle height	H101	1348 (53 1)	1352 (53 2)
Cowl point to ground	H114	949 (37 4), 948 (37 3) w/GT	948 (37 3), 947 (37 3) w/GT
Deck point to ground	H138	1005 (39 6), 1004 (39 5) w/GT	1016 (40 0), 1015 (39 9) w/GT
Rocker panel front to ground	H115	175 (6 9)	
Rocker panel-rear to ground	H116	176 (7 0)	175 (6 9)
Windshield slope angle (degrees)	H122	63 7°	
Backlight slope angle (degrees)	H121	66 3°	62 5°
<b>Ground Clearance*</b>			
Front bumper to ground	H102	251 (9 8), 249 (9 8) w/GT	250 (9 8), 249 (9 8) w/GT
Rear bumper to ground	H104	302 (11 9)	303 (11 9), 302 (11 9) w/GT
Bumper to ground front at curb mass (wt)	H103	264 (10 4)	261 (10 3)
Bumper to ground rear at curb mass (wt)	H105	345 (13 6)	345 (13 6)
Angle of approach (degrees)	H106	15 6°, 15 5° w/GT	15 5°, 15 4° w/GT
Angle of departure (degrees)	H107	14 7°	16 8°, 14 6° w/GT
Ramp breakover angle (degrees)	H147		
Axle differential to ground (front/rear)	H153	43 3 (1 7)	39 3 (1 5)
Min running ground clearance	H156	108 0 (4 3), 116 (4 6) w/GT	91 0 (3 6), 101 0 (4 0) w/GT
Location of min run grd clear		LH Underbody Catalyst	X-Brace

\* All vehicle height and ground clearances are measured at the Manufacturer's Design Load Weight. Manufacturer's Design Load Weight is defined with indicated passenger distribution and trunk/cargo load unless otherwise specified. All linear dimensions are in millimeters (inches) unless otherwise noted.



# Specifications

Vehicle Line MUSTANG  
 Model Year 2002 Issued 10/02 Revised (\*) \_\_\_\_\_

**METRIC (U.S. Customary)**  
**Vehicle Dimensions** See Key Sheets for definitions

Model Code/Description	COUPE (BASE AND GT)	CONVERTIBLE (BASE AND GT)
------------------------	---------------------	---------------------------

Front Compartment	SAE Ref No		
SgRP front "X" coordinate	L31	3050 (41 3)	
Effective head room	H61	968 (38 1)	966 0 (38 0)
Max eff leg room (accelerator)	L34	1081 (42 6) (a)	
SgRP to heel point	H30	221 (8 7)	
SgRP to heel point	L53	887 (34 9)	
Back angle (degrees)	L40	24°	
Hip angle (degrees)	L42	95 7°	
Knee angle (degrees)	L44	129 2°	
Foot angle (degrees)	L46	87°	
Design H point front travel	L17	206 (8 1)	
Normal driving & riding seat track trvl	TL23	177 (7 0)	
Shoulder room	W3	1362 (53 6)	
Hip room	W5	1329 (52 3)	1329 (52 3)
Upper body opening to ground	H50	1201 (47 3), 1200 (47 2) w/GT	1203 (47 4), 1202 (47 3) w/GT
Steering wheel maximum diameter*	W9	380 (15 0)	
Steering wheel angle (degrees)	H18	21°	
Accel heel pt to steer whl cntr	L11	538 (21 2)	
Accel heel pt to steer whl cntr	H17	606 (23 9)	
Depressed floor covering thickness	H68	20 (0 8)	

Rear Compartment			
SgRP point couple distance	L50	684 (26 9)	
Effective head room	H63	901 (35 5)	909 (35 8)
Min effective leg room	L51	758 (29 9)	
SgRP (second to heel)	H31	276 (10 9)	
Knee clearance	L48	-64 (-2 5)	
Shoulder room	W4	1324 (52 1)	1051 (41 4)
Hip room	W6	1203 (47 4)	1040 (41 0)
Upper body opening to ground	H51		
Back angle (degrees)	L41	24°	22°
Hip angle (degrees)	L43	76 4°	74 4°
Knee angle (degrees)	L45	66 9°	
Foot angle (degrees)	L47	110 1°	
Depressed floor covering thickness	H73	20 (0 8)	

Luggage Compartment			
Usable luggage capacity L (cu ft)	V1	308 (10 9)	219 2 (7 7)
Liftover height	H195	716 (28 2), 715 (28 1) w/GT	715 (28 1)

Interior Volumes (EPA Classification)			
Vehicle class		Subcompact	
Interior volume index including trunk/cargo (cu ft)**		93 9	N / A
Trunk/cargo index (cu ft)		10 9	7 7

\* See page 14  
 \*\* See definition page 33  
 All linear dimensions are in millimeters (inches) unless otherwise noted

(a) 1064 (41 9) with manual transmission which includes "Heel-to-Toe" performance feature on GT models

# Specifications

Vehicle Line MUSTANG  
 Model Year 2002 Issued 10/02 Revised (\*) \_\_\_\_\_

**METRIC (U.S. Customary)**  
**Vehicle Dimensions** See Key Sheets for definitions

Model Code/Description

SAE  
Ref  
No

**ALL MODELS**

Station Wagon/MPV\*

- Third Seat

(NOT APPLICABLE)

Seat facing direction	SD1
SgRP couple distance	L85
Shoulder room	W85
Hip room	W86
Effective leg room	L86
Effective head room	H86
SgRP to heel point	H87
Knee clearance	L87
Back angle (degrees)	L88
Hip angle (degrees)	L89
Knee angle (degrees)	L90
Foot angle (degrees)	L91

**Station Wagon/MPV\* - Cargo Space (NOT APPLICABLE)**

Cargo length (open front)	L200
Cargo length (open second)	L201
Cargo length (closed front)	L202
Cargo length (closed second)	L203
Cargo length at belt (front)	L204
Cargo length at belt (second)	L205
Cargo width (wheelhouse)	W201
Rear opening width at floor	W203
Opening width at belt	W204
Min rear opening width above belt	W205
Cargo height	H201
Rear opening height	H202
Tailgate to ground height	H250
Front seatback to load floor height	H197
Cargo volume index m <sup>3</sup> (ft <sup>3</sup> )	V2
Hidden cargo volume index m <sup>3</sup> (ft <sup>3</sup> )	V4
Cargo volume index-rear of 2 seat	V10
Cargo volume index*	V6
Cargo width at floor*	W500
Maximum cargo height*	H505

**Hatchback - Cargo Space**

(NOT APPLICABLE)

Cargo length at front seatback height	L208
Cargo length at floor (front)	L209
Cargo length at second seatback height	L210
Cargo length at floor (second)	L211
Front seatback to load floor height	H197
Second seatback to load floor height	H198
Cargo volume index m <sup>3</sup> (ft <sup>3</sup> )	V3
Hidden cargo volume index m <sup>3</sup> (ft <sup>3</sup> )	V4
Cargo volume index rear of 2-seat	V11

All linear dimensions are in millimeters (inches) unless otherwise noted  
 \* MPV Multipurpose Vehicle

# Specifications

Vehicle Line MUSTANG  
 Model Year 2002 Issued 10/02 Revised (\*) \_\_\_\_\_

## METRIC

Model Code/  
Description

ALL MODELS

## Vehicle Fiducial Marks

Fiducial Mark Number*	Define Coordinate Location
-----------------------	----------------------------

Front(1)	<p>The rear vertical edge of the master control notch on the underside of the front door rocker panels locates the "X" coordinate relative to body grd and is located at the 2315 (91 1) line</p> <p>(Front Location)            X = 2315 (91 1)            Y = 823 (32 4)            Z = 437 (17 2)</p>
Front(2)	
Rear(1)	<p>(Rear Location)            X = 3720 (146 5)            Y = 837 (32 9)            Z = 438 (17 2)</p>
Rear(2)	

Note Provide 3 of 4 Fiducial Mark Locations: The intersection of the horizontal-vertical surfaces on the rocker panel door rabbet locates the "Y" and "Z" coordinates relative to body grd at particular fore-aft inch lines. The fore-aft location can be determined by the reference dimension from Fiducial Mark 1 and 2

Front	W21**	823 (32 4)
	L54**	2315 (91 1)
	H81**	437 (17 2)
	H161**	—
	H163**	—

Rear	W22**	837 (32 9)
	L55**	3720 (146 5)
	H82**	438 (17 2)
	H162**	—
	H164**	—

\* Reference - SAE Recommended Practice J182a Motor Vehicle Fiducial Marks  
 \*\* Reference - SAE Recommended Practice J1100 Motor Vehicle Dimensions  
 All linear dimensions are in millimeters (inches) unless otherwise noted

# Specifications

Vehicle Line MUSTANG  
 Model Year 2002 Issued 10/02 Revised (\*) \_\_\_\_\_

## METRIC (U.S. Customary)

		Vehicle Mass (weight)				% PASS MASS DISTRIBUTION				
Code	Model	CURB MASS kg (lb)*			SHIPPING MASS kg(lb)***	ETWC** Code	Pass in Front		Pass in Rear	
		Front	Rear	Total			Front	Rear	Front	Rear
3 8L Engine - 100A/110A/120A/ 150A/160A										
5-Speed Manual Trans - Standard										
100A/110A/120A	P40	788	603	1391	1335	T	45	55	19	81
Mustang Model		(1737)	(1329)	(3066)	(2945)					
2-Door Coupe										
150A/160A	P44	809	646	1455	1400	V	45	55	19	81
Mustang Model		(1784)	(1424)	(3208)	(3086)					
2-Door Convertible										
3 8L Engine - 100A/110A/120A/ 150A/160A										
4-Speed Auto Trans - Optional 44U										
100A/110A/120A	P40	810	608	1418	1363	U	45	55	19	81
Mustang Model		(1786)	(1341)	(3127)	(3005)					
2-Door Coupe										
150A/160A	P44	837	645	1482	1427	V	45	55	19	81
Mustang Model		(1845)	(1423)	(3268)	(3146)					
2-Door Convertible										
4 6L (SOHC) Engine - 130A/140A/ 170A/180A										
5-Speed Manual Trans - Standard										
130A/140A	P42	828	642	1470	1412	V	45	55	19	81
Mustang GT Model		(1825)	(1416)	(3241)	(3114)					
2-Door Coupe										
170A/180A	P45	854	678	1532	1475	X	45	55	19	81
Mustang GT Model		(1884)	(1495)	(3379)	(3252)					
2-Door Convertible										

\* Reference - SAE J1100 Motor vehicle dimensions curb weight definition

\*\* ETWC - Equivalent Test Weight Class - basis for U.S. Environmental Protection Agency emission certifications  
 Refer to ETWC code legend below for test weight class

### ETWC LEGEND

A = 1000	I = 2000	Q = 3000	Y = 4000
B = 1125	J = 2125	R = 3125	Z = 4250
C = 1250	K = 2250	S = 3250	AA = 4500
D = 1375	L = 2375	T = 3375	BB = 4750
E = 1500	M = 2500	U = 3500	CC = 5000
F = 1625	N = 2625	V = 3625	DD = 5250
G = 1750	O = 2750	W = 3750	EE = 5500
H = 1875	P = 2875	X = 3875	FF = 5750

\*\*\*Shipping Mass (weight) = Curb Weight Less

57 (125) w/3 8L Engine

58 (128) w/4 6L (SOHC) Engine

# Specifications

Vehicle Line MUSTANG  
 Model Year 2002 Issued 10/02 Revised (\*) \_\_\_\_\_

## METRIC (U.S. Customary)

		Vehicle Mass (weight)				% PASS MASS DISTRIBUTION				
Code	Model	CURB MASS kg (lb)*			SHIPPING MASS kg(lb)***	ETWC** Code	Pass in Front		Pass in Rear	
		Front	Rear	Total			Front	Rear	Front	Rear
4 6L (SOHC) Engine - 130A/140A/170A/180A										
4-Spd Auto Trans - Optional 44U										
130A/140A	P42	844	646	1490	1432	W	45	55	19	81
Mustang GT Model		(1860)	(1425)	(3285)	(3158)					
2-Door Coupe										
170A/180A	P45	870	684	1554	1497	X	45	55	19	81
Mustang GT Model		(1919)	(1508)	(3427)	(3300)					
2-Door Convertible										

\* Reference - SAE J1100 Motor vehicle dimensions curb weight definition  
 \*\* ETWC - Equivalent Test Weight Class - basis for U S Environmental Protection Agency emission certifications  
 Refer to ETWC code legend below for test weight class

### ETWC LEGEND

A = 1000	I = 2000	Q = 3000	Y = 4000
B = 1125	J = 2125	R = 3125	Z = 4250
C = 1250	K = 2250	S = 3250	AA = 4500
D = 1375	L = 2375	T = 3375	BB = 4750
E = 1500	M = 2500	U = 3500	CC = 5000
F = 1625	N = 2625	V = 3625	DD = 5250
G = 1750	O = 2750	W = 3750	EE = 5500
H = 1875	P = 2875	X = 3875	FF = 5750

\*\*\*Shipping Mass (weight) = Curb Weight Less  
 58 (128) w/4 6L (SOHC) Engine

# Specifications

Vehicle Line MUSTANG  
Model Year 2002 Issued 10/02 Revised (\*) \_\_\_\_\_

## METRIC (U.S. Customary)

		Optional Equipment Differential Mass (weight)*			
		MASS kg (lb)			
Code	Equipment	Front	Rear	Total	Remarks Restrictions Requirements
<b>Wheels</b>					
64J	Wheels, Forged Aluminum, 17" x 8 0" with Tires	2 9 (6 4)	2 9 (6 4)	5 8 (12 8)	
<b>Brakes</b>					
552	Anti-Lock Brake System	6 26 (13 8)	49 (1 08)	6 75 (14 88)	
<b>Radio Systems</b>					
586	MACH 460 Premium AM/FM Stereo and Cassette w/ Coupe	9 3 (20 4)	11 8 (26 0)	21 1 (46 4)	
586	MACH 460 Premium AM/FM Stereo and Cassette w/ Convertible	9 3 (20 4)	11 4 (25 0)	20 6 (45 4)	

\* Also see Engine General Section for dressed engine mass (weight)

**Specifications**  
**METRIC (U.S. Customary)**

**Exterior Vehicle And Body Dimensions - Key Sheet**

*Exterior Width Dimensions*

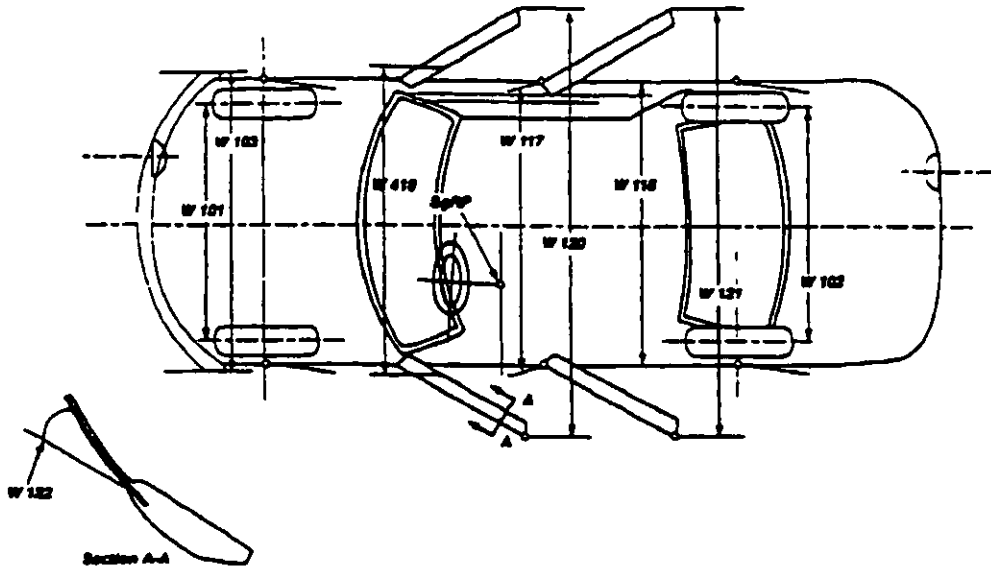

*Exterior Length & Height Dimensions*

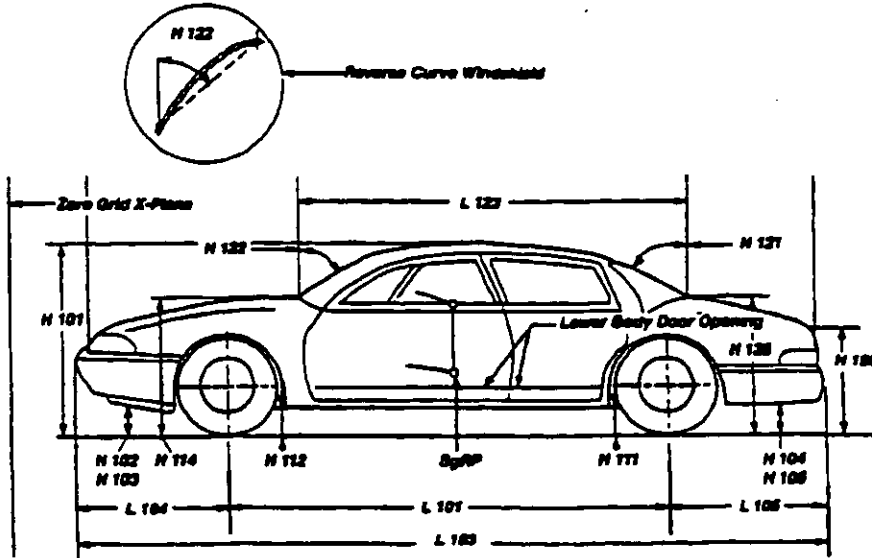

*Ground Clearance Dimensions*

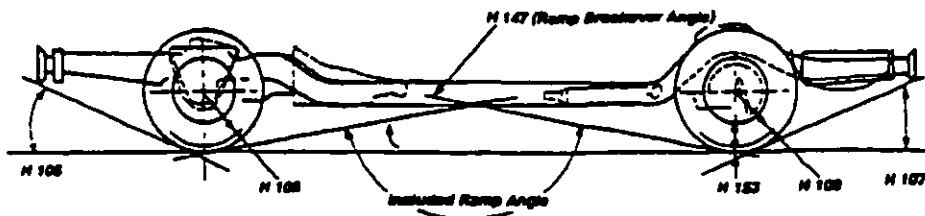

# Specifications METRIC (U.S. Customary)

## 1910r Vehicle And Body Dimensions - Key Sheet

Interior Length Dimensions

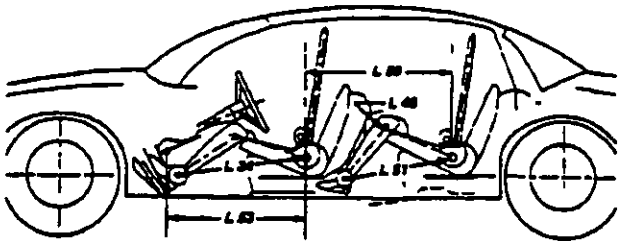

Interior Height Dimensions

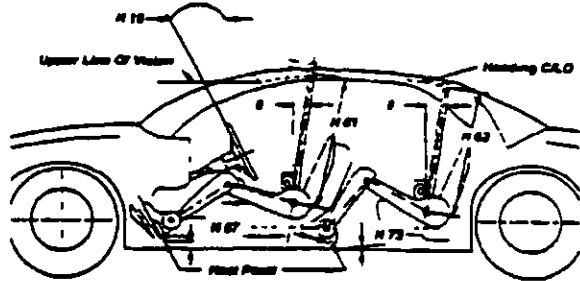

Interior Height Dimensions

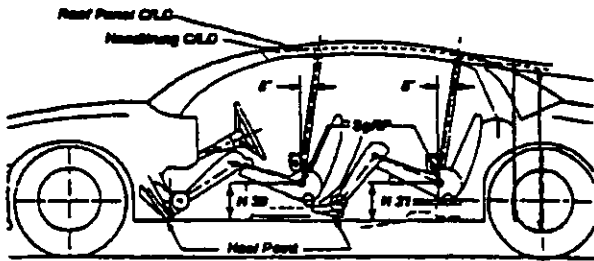

Interior Length Dimensions

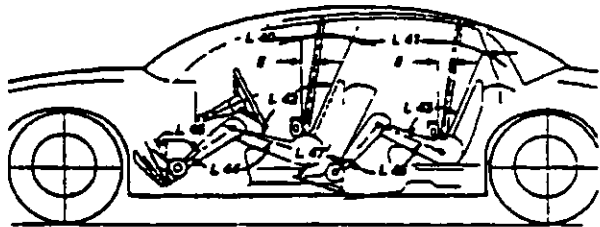

Interior Width Dimensions

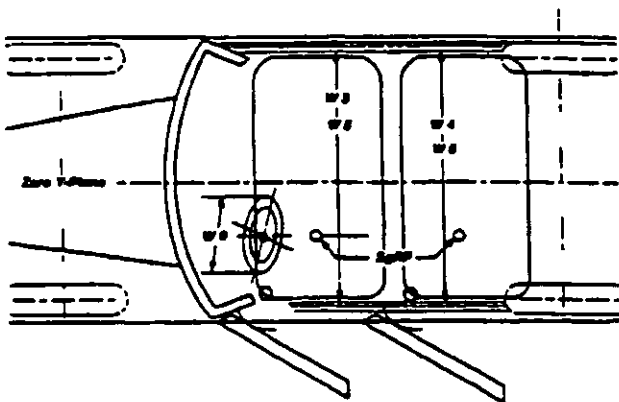

Interior Height Dimensions

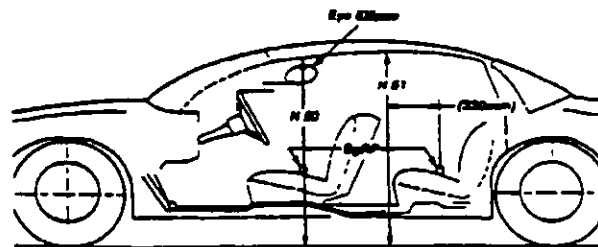



# Specifications

## METRIC (U.S. Customary)

### Interior Vehicle And Body Dimensions - Key Sheet

Interior Dimensions, Station Wagon Third Seat

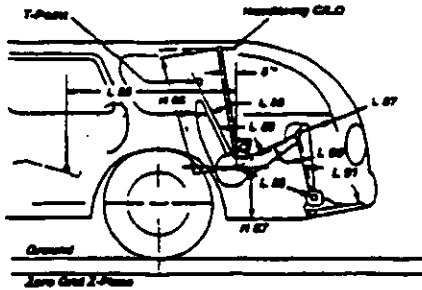

Interior Dimensions

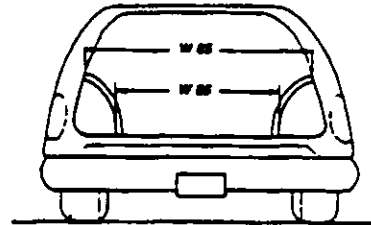

Cargo Space Dimensions

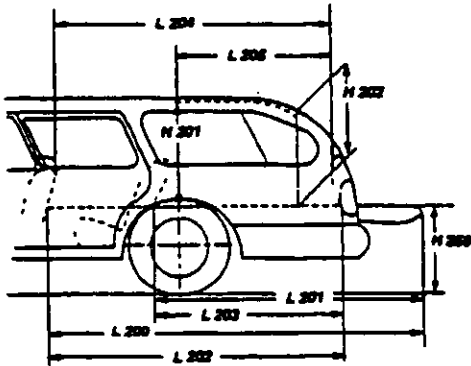

Cargo Space Dimensions

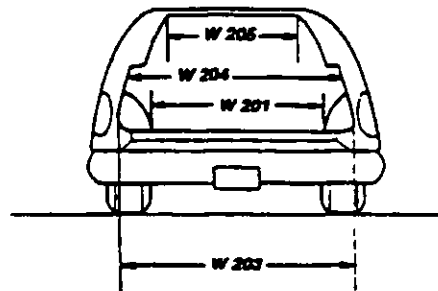

Cargo Space Dimensions

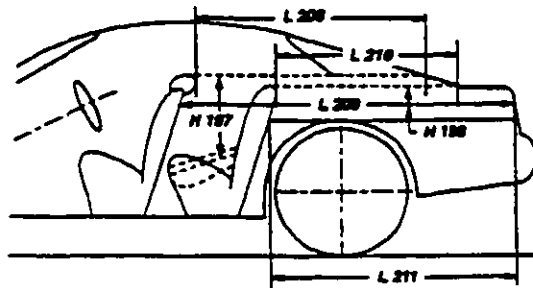

Multipurpose Vehicle Cargo Space

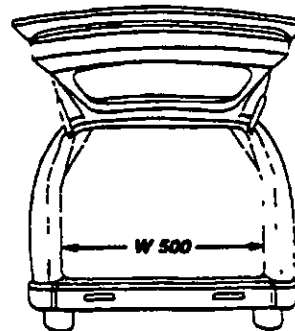
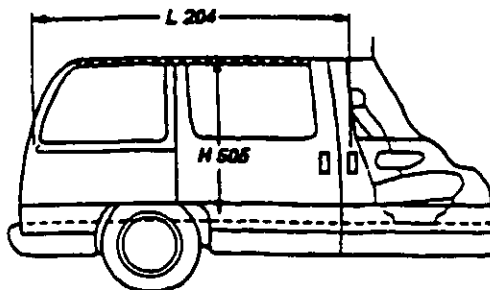

# Specifications

## METRIC (U. S. Customary)

### Exterior Vehicle And Body Dimensions - Key Sheet Dimensions Definitions

#### Seating Reference Point

SEATING REFERENCE POINT means the manufacturer's design reference point which -

- (a) Establishes the rearmost normal design driving or riding position of each designated seating position in a vehicle,
- (b) Has coordinates established relative to the design vehicle structure,
- (c) Simulates the position of the pivot center of the human torso and thigh, and
- (d) is the reference point employed to position the two dimensional templates described in SAE Recommended Practice J826, "Devices for Use in Defining and Measuring Vehicle Seating Accommodations."

#### Width Dimensions

- W101 TREAD-FRONT The dimension measured between the tire centerlines at the ground
- W102 TREAD-REAR The dimension measured between the tire centerlines at the ground. In case of dual wheels, the dimension will be measured to the centerline of tire and wheel assemblies
- W103 VEHICLE WIDTH The maximum dimension measured between the widest point on the vehicle, excluding exterior mirrors, flexible mud flaps, marker lamps, but including bumpers, moldings, sheet metal protrusions or dual wheels, if standard equipment
- W117 BODY WIDTH AT SgRP-FRONT The dimension measured laterally between the widest points on the body at the SGRP-front, excluding door handles, applied moldings, or appliques
- W120 VEHICLE WIDTH-FRONT DOORS OPEN The dimension measured between the widest point on the rear doors in maximum hold-open position
- VEHICLE WIDTH-REAR DOORS OPEN The dimension measured between the widest point on the rear doors in maximum hold-open position. For vehicles with a rear door on only one side, this dimension is to the zero "Y" plane
- W122 TUMBLE-HOME STRAIGHT SIDE GLASS The angle measured from a vertical to the outside surface of the front door glass at the SgRP "X" plane
- CURVED SIDE GLASS The angle measured from a vertical to a chord extending from the upper DLO to the lower DLO at the outside surface of the front door glass at the front SgRP "X" plane
- W410 OUTSIDE MIRROR WIDTH The dimension between the widest point on the outside mirrors. The standard right and left mirror adjusted for normal driving will be shown unless otherwise noted. When only one outside mirror is standard the dimension will be to the zero "Y" plane

#### Length Dimensions

- 101 WHEELBASE (WB) The dimension measured longitudinally between front and rear wheel centerline. In case of dual rear axles, the dimension shall be to the midpoint of the centerlines of the rear wheels
- 103 VEHICLE LENGTH The maximum dimension measured longitudinally between the foremost point and the rearmost point on the vehicle including bumper, bumper guards, tow hooks and/or rub strips if standard equipment
- 104 OVERHANG-FRONT The dimension measured longitudinally from the centerline of the front wheels to the foremost point on the vehicle including bumper, bumper guards, tow hook and/or rub strips, if standard equipment
- 105 OVERHANG-REAR The dimension measured longitudinally from the centerline of the rear wheels, or in the case of dual rear axles, the dimension shall be the midpoint of the centerlines of the rear wheels, to the rearmost point on the vehicle including rear bumpers, bumper guards, tow hooks and rub strips, if standard equipment
- 123 UPPER STRUCTURE LENGTH The dimension measured longitudinally from the cowl point to the deck point

- L127 REAR WHEEL CENTERLINE "x" COORDINATE or in the case of dual rear axles the coordinate shall be the midpoint of the distance between the rear axle centerlines

#### Height Dimensions

- H101 VEHICLE HEIGHT The dimension measured vertically from the highest point on the vehicle body to ground
- H111 ROCKER PANEL-REAR TO GROUND The dimension measured vertically from the bottom of the rocker or side quarter panel at the front of the rear wheel opening, excluding flanges to ground
- H112 ROCKER PANEL-FRONT TO GROUND The dimension measured vertically from the foremost point on the bottom of the rocker panels excluding flanges to ground
- H114 COWL POINT TO GROUND Measured at zero "Y" plane
- H121 BACKLIGHT SLOPE ANGLE The angle between the vertical reference line and the surface of backlight at vehicle zero "Y" plane. For curve backlight the angle is to chord of backlight arc from lower DLO to upper DLO
- H122 WINDSHIELD SLOPE ANGLE The angle between the vertical reference line and a chord of the windshield arc running from the lower DLO to the upper DLO at the vehicle zero "Y" plane. In the case of wrap over glass the angle to be measured will be formed by a chord 457 mm (18 0 in) long drawn from the lower DLO to the intersecting point on the windshield
- H138 DECK POINT TO GROUND Measured at zero "Y" plane
- H109 STATICLOAD-TIRE RADIUS-REAR Specified by the manufacturer in accordance with composite TIRE SECTION STANDARD

#### Ground Clearance Dimensions

- H102 FRONT BUMPER TO GROUND The minimum dimension measured vertically from the lowest point on the front bumper to ground, including bumper guards, if standard equipment
- H103 FRONT BUMPERTOGROUND-CURBMASS(WT) Measured in the same manner as H102
- H104 REAR BUMPER TO GROUND The minimum dimension measured vertically from the lowest point on the rear bumper to ground, including bumper guards, if standard equipment
- H105 REAR BUMPER TO GROUND-CURB MASS(WT) Measured in the same manner as H104
- H106 ANGLE OF APPROACH The angle measured between a line tangent to the front tire static loaded radius arc and the initial point of structural interference forward of the front tire to ground. The limiting structural component shall be designated
- H107 ANGLE OF DEPARTURE The angle measured between a line tangent to the rear tire static loaded radius arc and the initial point of structural interference rearward of the rear tire to ground. The limiting component shall be designated
- H147 RAMP BREAKOVER ANGLE The angle measured between two lines tangent to the front and rear tire static loaded radius and intersecting at a point on the underside of the vehicle which defines the largest ramp over which the vehicle can roll
- H153 REAR AXLE DIFFERENTIAL TO GROUND The minimum dimension measured from the rear axle differential to ground
- H156 MINIMUM RUNNING GROUND CLEARANCE The minimum dimension measured from the sprung vehicle to ground. Specify location

# Specifications

METRIC (U. S. Customary)

## Interior Vehicle And Body Dimensions - Key Sheet

### Dimensions Definitions

#### Glass Areas

- S1 Windshield area
- S2 Side windows area Includes the front door rear door, vents, and rear quarter windows on both sides of the vehicle
- S3 Backlight areas
- S4 Total area Total of all areas (S1 + S2 + S3)

#### Fiducial Mark Dimensions

- Fiducial Mark - Number 1
- L54 "X" coordinate
- W21 "Y" coordinate
- H81 "Z" coordinate
- H161 Height "Z" coordinate to ground at curb weight
- H163 Height "Z" coordinate to ground
- Fiducial Mark - Number 2
- L55 "X" coordinate
- W22 "Y" coordinate
- H82 "Z" coordinate
- H162 Height "Z" coordinate to ground at curb weight
- H164 Height "Z" coordinate to ground

#### Front Compartment Dimensions

- L11 ACCELERATOR WHEEL POINT TO STEERING WHEEL CENTER The dimension measured horizontally from the AHP to the intersection of the steering column centerline and a plane tangent to the upper surface of the steering wheel rim
- L17 DESIGN-H-POINT-FRONT TRAVEL The dimension measured horizontally between the design H-point-front in the foremost and rearmost seat track positions (See SAE J1100)
- L23 NORMAL DRIVING AND RIDING SEAT TRACK TRAVEL The dimension measured horizontally between a point on the design H-point travel line from the SgRP to the displaced point on the design H-point travel line with the seat moved to the foremost seat position, but not to include seat track travel used for purposes other than normal driving and riding positions (See SAE J1100)
- L31 SgRP-Front "X" Coordinated
- L34 MAXIMUM EFFECTIVE LEG ROOM-ACCELERATOR The dimension measured along a line from the ankle pivot center to the SgRP-front plus 254 mm (10 0 in ) measured with right foot on the undepressed accelerator pedal For vehicles with SgRP to heel (H30) greater than 18 in , the accelerator pedal may be depressed as specified by the manufacturer If the accelerator is depressed, the manufacturer shall place foot flat on pedal and note the depression of the pedal
- L40 BACK ANGLE-FRONT The angle measured between a vertical line through the SgRP-front and the torso line If the seatback is adjustable, use the normal driving and riding position specified by the manufacturer
- L42 HIP ANGLE-FRONT The angle measured between torso line and thigh centerline
- L44 KNEE ANGLE-FRONT The angle measured between thigh centerline and lower leg centerline measured on the right leg
- L46 FOOT ANGLE-FRONT The angle measured between the lower leg centerline and a line tangent to the ball and heel of the bare foot flesh line measured on the right leg Ref SAE J826
- L53 SgRP-FRONT TO HEEL The dimension measured horizontally from the SgRP-front to the accelerator heel point
- W3 SHOULDER ROOM-FRONT The minimum dimension measured laterally between the trimmed surfaces on the "X" plane through the SgRP-front at height between the belt line and 254 mm (10 0 in ) above the SgRP-front, excluding the door assist strap and attaching parts

- W5 HIP ROOM-FRONT The minimum dimension measured laterally between the trimmed surfaces on the "X" plane through the SgRP-front within 25 mm (1 0 in ) below and 76 mm (3 0 in ) above the SgRP-front and 76 mm (3 0 in ) fore and aft of the SgRP front
- W9 STEERING WHEEL MAXIMUM OUTSIDE DIAMETER Define if other than round
- H7 ACCELERATOR HEEL POINT TO THE STEERING WHEEL CENTER The dimension measured vertically from the AHP front to the intersection of the steering column centerline to a plane tangent to the upper surface of the steering wheel rim
- H18 STEERING WHEEL ANGLE The angle measured from a vertical to the surface plane of the steering wheel
- H30 SgRP-FRONT TO HEEL The dimension measured vertically from the SgRP-front to the accelerator heel point
- H50 UPPER BODY OPENING TO GROUND-FRONT The dimension measured vertically from the trimmed body opening to the ground on the SgRP-front "X" plane
- H61 EFFECTIVE HEAD ROOM-FRONT The dimension measured along a line 8 deg rear of vertical from the SgRP-front to the headlining plus 102 mm (4 0 in )
- H67 FLOOR COVERING THICKNESS - UNDEPRESSED - FRONT The dimension measured vertically from the surface of the undepressed floor covering to the underbody sheet metal at the accelerator heel point

#### Rear Compartment Dimensions

- L41 BACK ANGLE-SECOND The angle measured between a vertical line through the SgRP-second and the torso line
- L43 HIP ANGLE-SECOND The angle measured between torso line and thigh centerline
- L45 KNEE ANGLE-SECOND The angle measured between thigh centerline and lower leg centerline
- L47 FOOT ANGLE-SECOND The angle measured between the lower leg centerline and a line tangent to the ball and heel of the three-dimensional devices bare foot flesh line (Reference J826)
- L48 KNEE CLEARANCE-SECOND The minimum dimension measured from the knee pivot center to the back of the front seatback minus 51 mm (2 0 in )
- L50 SgRP COUPLE DISTANCE-SECOND The dimension measured horizontally from the driver SgRP-front to the SgRP-second
- L51 MINIMUM EFFECTIVE LEG ROOM-SECOND The dimension measured along a line from the ankle pivot center to the SgRP-second plus 254 mm (10 0 in )
- W4 SHOULDER ROOM-SECOND The minimum dimension measured laterally between door or quarter trimmed surfaces on the "X" plane through the SgRP-second at height between 254-406 mm (10 0-16 0 in ) above the SgRP-second, excluding the door assist straps and attaching parts
- W6 HIP ROOM-SECOND Measured in the same manner as W5
- H31 SgRP-SECOND TO HEEL The dimension measured vertically from the SgRP second to the two dimensional device heel point on the depressed floor covering
- H51 UPPER BODY OPENING TO GROUND-SECOND The dimension measured vertically from the trimmed body opening to the ground on the "X" plane 330 mm (13 0 in ) forward of the SgRP-second
- H63 EFFECTIVE HEAD ROOM-SECOND The dimension measured along a line 8 deg rear of vertical from the SgRP to the headlining, plus 102 mm (4 0 in )
- H73 FLOOR COVERING-DEPRESSED-SECOND The dimension measured vertically from the heel point to the underbody sheet metal

# Specifications

METRIC (U. S. Customary)

## Major Vehicle And Body Dimensions - Key Sheet

### Dimensions Definitions

#### Luggage Compartment Dimensions

V1 **USABLE LUGGAGE CAPACITY**-Total of volume of individual pieces of standard luggage set plus H-boxes stowed in the luggage compartment in accordance with the procedure described in paragraph 8.2 of SAE-J1100a

#### Interior Volumes (EPA Classification)

The interior index is listed for each body style except two seaters. The interior volume index estimates the space in a car. It is based on our measurements - head room, shoulder room, hip room, and leg room - for the front and rear seats, plus trunk capacity.

The Trunk/Cargo Index is an estimate of the size of the trunk/cargo space. In station wagons and hatchbacks it is an estimate of the space behind the second seat.

#### Station Wagon/MPV - Third Seat Dimensions

L85 **SgRP COUPLE DISTANCE-THIRD** The dimension measured horizontally from the SgRP-second to the SgRP-third.

L86 **EFFECTIVE LEG ROOM-THIRD** The dimension measured along a line from the ankle pivot center to the SgRP-third plus 254 mm (10.0 in).

L87 **KNEE CLEARANCE-THIRD** The minimum dimension from the knee pivot center to the back of second seatback minus a constant of 51 mm (2.0 in). With rear-facing third seat, dimension is measured to closure.

L41 **BACK ANGLE-THIRD** Measured in the same manner as L41.

L89 **HIP ANGLE-THIRD** Measured in the same manner as L43.

L90 **KNEE ANGLE-THIRD** Measured in the same manner as L45.

L91 **FOOT ANGLE-THIRD** Measured in the same manner as L47.

W85 **SHOULDER ROOM-THIRD** Measured in the same manner as W4.

W86 **HIP ROOM-THIRD** Measured in the same manner as W5.

L86 **EFFECTIVE HEAD ROOM-THIRD** The dimension, measured along a line 8 deg from the SgRP-third to the headring rear of vertical plus a constant of 102 mm (4.0 in).

L87 **SgRP-THIRD TO HEEL POINT**

D1 **SEAT FACING DIRECTION-THIRD**

#### Station Wagon/MPV - Cargo Space Dimensions

200 **CARGO LENGTH-OPEN-FRONT** The minimum dimension measured longitudinally from the back of the front seatback at the height of the undepressed floor covering to the rearmost point on the undepressed floor covering on the open tailgate or cargo surface if the rear closure is a conventional door type tailgate at the zero "Y" plane.

201 **CARGO LENGTH-OPEN-SECOND** The dimension measured longitudinally from the back of the second seatback at the height of the undepressed floor covering on the open tailgate or cargo floor surface if the rear closure is a conventional door type tailgate, at the zero "Y" plane.

L202 **CARGO LENGTH-CLOSED-FRONT** The minimum dimension measured horizontally from the back of the front seat at the height of the undepressed floor covering to the rearmost point on the undepressed floor covering on the closed tailgate or taildoor for station wagons, trucks and mpv's at the zero "Y" plane.

L203 **CARGO LENGTH-CLOSED-SECOND** The dimension measured horizontally from the back of the second seat at the height of the undepressed floor covering to the rearmost point on the undepressed floor covering on the closed tailgate or taildoor for station wagons, trucks and mpv's at the zero "Y" plane.

L204 **CARGO LENGTH AT BELT-FRONT** The minimum dimension measured horizontally from the back of the front seatback at the seatback top to the foremost normal surface of the closed tailgate or inside surface of the cab backpanel at the height of the belt, on the zero "Y" plane.

L205 **CARGO LENGTH AT BELT-SECOND** The minimum dimension measured horizontally from the back of the second seatback top to the foremost normal surface of the closed tailgate at the height of the belt, on the zero "Y" plane.

W201 **CARGO WIDTH-WHEELHOUSE** The minimum dimension measured laterally between the trimmed wheelhousings at floor level. For any vehicle not trimmed, measure to the sheet metal.

W203 **REAR OPENING WIDTH AT FLOOR** The minimum dimension measured laterally between the limiting interferences of the rear opening at floor level.

W204 **REAR OPENING WIDTH AT BELT** The minimum dimension measured laterally between the limiting interferences of the rear opening at belt height or top of pick up box.

W205 **REAR OPENING WIDTH ABOVE BELT** The minimum dimension measured laterally between the limiting interferences of the rear opening above the belt height.

W500 **CARGO WIDTH AT FLOOR** The maximum dimension measured laterally between the limiting interferences at the floor level. This dimension shall include ribs and pillars, but will exclude wheelhouses.

H197 **FRONT SEATBACK TO LOAD FLOOR HEIGHT** The dimension measured vertically from the horizontal tangent to the top of the seatback to the undepressed floor covering.

H201 **CARGO HEIGHT** The dimension measured vertically from the top of the undepressed floor covering to the headlining at the rear wheel "X" coordinate on the zero "Y" plane.

H202 **REAR OPENING HEIGHT** The dimension measured vertically from the top of the undepressed floor covering to the upper trimmed opening on the zero "Y" plane with rear door fully open.

H250 **TAILGATE TO GROUND CURB MASS (WT)** The dimension measured vertically from the top of the undepressed floor covering on the lowered tailgate to ground on the zero "Y" plane.

H505 **MAXIMUM CARGO HEIGHT** The maximum vertical dimension rear of the front seat from the cargo floor to roof bow or headlining at the zero "Y" plane.

# Specifications

METRIC (U. S. Customary)

## Interior Vehicle And Body Dimensions - Key Sheet

### Dimensions Definitions

<p>V2 STATION WAGON Measured in inches</p> $\frac{W4 \times H201 \times L204}{1728} = ft^3$ <p>Measured in mm</p> $\frac{W4 \times H201 \times L204}{10^9} = m^3(\text{cubicmeter})$	<p>L208 CARGO LENGTH AT FRONT SEATBACK HEIGHT The minimum horizontal dimension from the "X" plane tangent to the rearmost surface of the driver's seatback to the inside limiting interference of the hatchback door on the vehicle zero "Y" plane</p> <p>L209 CARGO LENGTH AT FLOOR-FRONT The minimum horizontal dimension measured at floor level from the rear of the front seatback to the normal limiting interference of the hatchback door on the vehicle zero "Y" plane</p> <p>L210 CARGO LENGTH AT SECOND SEATBACK HEIGHT The minimum dimension measured from the "X" plane tangent to the rearmost surface of second seatback or the load floor which is towed at least one half of the H198 dimension height above the rear load floor, to the rearmost inside limiting interference on the zero "X" plane</p>
<p>V4 HIDDEN LUGGAGE CAPACITY-REAR OF FRONT SEAT The total volumes of individual pieces of one set of standard luggage stowed in any hidden cargo area below the load floor rear of the front seat</p> <p>V5 TRUCKS AND MPV'S WITH OPEN AREA Measured in inches</p> $\frac{L506 \times W505 \times H503}{1728} = ft^3$ <p>Measured in mm</p> $\frac{L506 \times W500 \times H503}{10^9} = m^3(\text{cubicmeter})$	<p>L211 CARGO LENGTH AT FLOOR-SECOND SEATBACK The minimum horizontal dimension measured at floor level from the rear of the second seatback or load floor panel to the normal limiting interference of the hatchback door on the vehicle zero "Y" plane</p> <p>H197 FRONT SEATBACK TO LOAD HEIGHT The dimension measured vertically from the horizontal tangent to the top of the seatback to the undepressed floor covering</p> <p>H198 SECOND SEATBACK TO LOAD FLOOR HEIGHT The dimension measured vertically from the second seatback to the undepressed floor covering</p>
<p>V6 TRUCKS AND MPV'S WITH CLOSED AREA Measured in inches</p> $\frac{L204 \times W500 \times H505}{1728} = ft^3$ <p>Measured in mm</p> $\frac{L204 \times W500 \times H505}{10^9} = m^3(\text{cubicmeter})$	<p>V3 HATCHBACK Measured in inches</p> $\frac{\frac{L208 + L209}{2} \times W4 \times H197}{1728} = ft^3$ <p>Measured in mm</p> $\frac{\frac{L208 + L209}{2} \times W4 \times H197}{10^9} = m^3(\text{cubicmeter})$
<p>V8 HIDDEN LUGGAGE CAPACITY-REAR OF SECOND SEAT The total volume of individual pieces of one set of standard luggage stowed in any hidden cargo area below the load floor rear of the second seat</p> <p>V10 STATION WAGON CARGO VOLUME INDEX Measured in inches</p> $\frac{H201 \times L205 \times \frac{W4 + W201}{2}}{1728} = ft^3$ <p>Measured in mm</p> $\frac{H201 \times L205 \times \frac{W4 + W201}{2}}{10^9} = m^3(\text{cubicmeter})$	<p>V4 HIDDEN LUGGAGE CAPACITY-REAR OF FRONT SEAT The total volumes of individual pieces of one set of standard luggage stowed in any hidden cargo area below the load floor rear of the front seat</p> <p>V11 HATCHBACK CARGO VOLUME INDEX Usable luggage (one (1) stand and luggage set) below floor Measured in inches</p> $\frac{\frac{L210 + L211}{2} \times W4 \times H198}{1728} = ft^3$ <p>Measured in mm</p> $\frac{\frac{L210 + L211}{2} \times W4 \times H198}{10^9} = m^3(\text{cubicmeter})$

### Hatchback - Cargo Space Dimensions

All Hatchback cargo dimensions are to be taken with the front seat in full down and rear position, and the rear seat folded down. The hatchback door is in the closed position. (For electronically adjusted seats, see the manufacturer's specifications for Design "H" Point)

# Specifications

\*METRIC (U. S. Customary)

## Index

Subject	Page No.	Subject	Page No.
Alternator	16	Passenger Capacity	1
Axle, Drive, Front, Rear, All Four	2, 9, 10	Passenger Mass Distribution	26
Axle Shafts	10	Pistons	3
Battery	16	Power Brakes	12
Body and Miscellaneous Information	17	Power Engine	2
Brakes-Parking Service	12, 13	Power Steering	14
Camber	15	Power Teams	2
Crankshaft	3	Propeller Shaft	10
Capacities		Pumps-Fuel	6
Cooling System	5	Water	5
Fuel Tank	6	Radiator-Cap, Hoses, Core	5
Lubricants		Rebo-Axle, Transaxle	2, 9, 10
Engine Crankcase	4	Compression	2
Transmission/Transaxle	8, 9	Steering	14
Rear Axle	10	Transmission/Transaxle	2, 8, 9
Carburetor	2, 6	Rear Axle	2, 10
Caster	15	Regulator-Alternator	16
Climate Control System	19	Restraint System	18
Clutch-Pedal Operated	8	Runs	13
Coil, Ignition	16	Rods-Connecting	4
Connecting Rods	4	Scrub Radius	14
Convenience Equipment	20-21	Seats	17
Cooling System	5	Shock Absorbers, Front & Rear	11
Crankshaft	4	Spark Plugs	16
Cylinders and Cylinder Head	3	Speedometer	15
Diesel Information	4	Springs-Front & Rear Suspension	11
Dimension Definitions		Stabilizer (Sway Bar)-Front & Rear	11
Key Sheet-Exterior	28, 31, 32	Starting System	16
Key Sheet-Interior	29, 30, 32, 33, 34	Steering	14
Electrical System	15, 16	Suppression-Ignition, Radio	16
Emission Controls	7	Suspension-Front & Rear	11
Engine-General		Tail Pipe	7
Bore, Stroke, Type	3	Theft Protection	21
Compression Ratio	2	Thermostat, Cooling	5
Placement	2, 3	Tires	13
Running Order, Cylinder Numbering	3	Toe-in	15
General Information, Power & Torque	2	Torque Converter	9
Intake System	4	Torque-Engine	2, 8, 9
Power Teams	2	Trailer Towing	21
Exhaust System	7	Transaxle	9
Equipment Availability, Convenience	20	Transmission-Types	2, 8, 9
Fan, Cooling	5	Transmission-Automatic	2, 9
Filters - Engine Oil, Fuel System	4	Transmission-Manual	2, 8
Four Wheel Drive	10	Transmission-Ratios	2, 8, 9
Frame	17	Tread	22
Front Suspension	11	Trunk Cargo Load	1
Front Wheel Drive Unit	10	Trunk Luggage Capacity	23
Fuel Economy, EPA	1	Turning Diameter	14
Fuel Injection	6	Unazed Construction	18
Fuel System	6	Universal Joints, Propeller Shaft	10
Fuel Tank	6	Valve System	4
Glass	18	Vehicle Dimensions	
Headlamps	18	Width	22
Headroom-Body	23, 24	Length	22
Heights	22	Height	22
Horns	15	Ground Clearance	22
Horsepower-Brake	2	Front Compartment	23
Ignition System	16	Rear Compartment	23
Inflation-Tires	13	Luggage Compartment	23
Interior Volumes	23	Station Wagon-Third Seat	24
Instruments	15	Station Wagon-Cargo Space	24
Legroom	23, 24	Hatchback-Cargo Space	24
Lengths	22	fiducial Marks	25
Leveling, Suspension	11	Voltage Regulator	16
Lifters, Valve	4	Water Pump	5
Linings-Clutch, Brake	8, 12	Weights	26, 27
Lubrication-Engine Transmission/Transaxle	4, 8, 9	Wheel Alignment	15
Luggage Compartment	23	Wheelbase	22
Models	1	Wheels & Tires	13
Motor Starting	16	Wheel Spindle	14
Muffler	7	Widths	22
Origin	1	Windshield	18
		Windshield Wiper and Washer	15